

Cyberprobe

for version 2.5.1, 6 June 2020

cybermagedon

This manual is for Cyberprobe (version 2.5.1, 6 June 2020), which is an example in the Texinfo documentation.

Copyright © 2013-2014 Cyber MacGeddon

Permission is granted to copy, distribute and/or modify this document under the terms of the GNU Free Documentation License, Version 1.3 or any later version published by the Free Software Foundation; with no Invariant Sections, with no Front-Cover Texts, and with no Back-Cover Texts.

Cyberprobe

This is the manual for Cyberprobe (version 2.5.1, 6 June 2020).

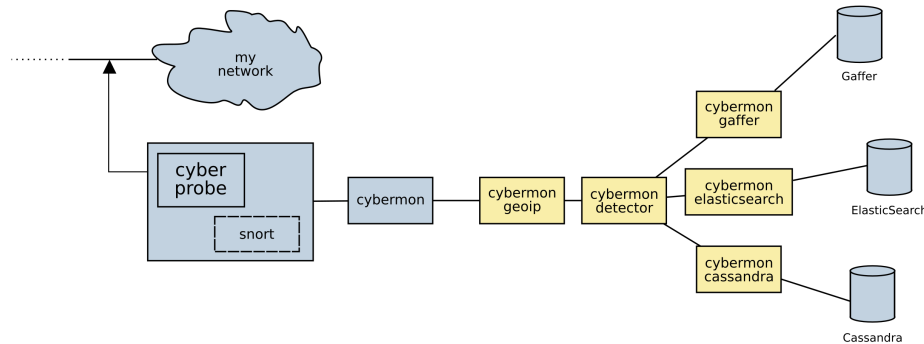

Cyberprobe is a network packet inspection toolkit (Deep Packet Inspection) for real-time monitoring of networks. This has applications in network monitoring, intrusion detection, forensic analysis, and as a defensive platform. Cyberprobe packet inspection works on physical networks, and also in cloud VPCs. There are features that allow cloud-scale deployments.

This is not a single, monolithic intrusion detection toolkit which does everything you want straight out of the box. If that's what you need, I would suggest you look elsewhere. Instead, Cyberprobe is a set of flexible components which can be combined in many ways to manage a wide variety of packet inspection tasks. If you want to build custom network analytics there are many interfaces that make this straightforward.

The project maintains a number of components, including:

- **cyberprobe**, which collects data packets and forwards them a network stream protocol in real time. Packet collection can be targeted with IP addresses, CIDR ranges or full-take. Collected packets are tagged with a device identifier. **cyberprobe** can be integrated with Snort to allow dynamic targeting of IP addresses in response to a Snort rule hitting.
- **cybermon**, which receives collected packet streams, performs stateful processing and creates a stream of observations describing network events. The events can be consumed in many different ways e.g. the events can be delivered to a pub/sub system, or presented to a gRPC service. The event handling is implemented as a function written in Lua, so you can add your own custom event handling.
- a set of subscribers which can be used to do things with the captured data e.g. store to ElasticSearch, Cassandra or Gaffer.

The architecture has support for AWS Traffic Mirroring, and supports cloud-scale deployments.

1 Overview

Summary

Cyberprobe is a network packet inspection toolkit (Deep Packet Inspection) for real-time monitoring of networks. This has applications in network monitoring, intrusion detection, forensic analysis, and as a defensive platform. Cyberprobe packet inspection works on physical networks, and also in cloud VPCs. There are features that allow cloud-scale deployments.

This is not a single, monolithic intrusion detection toolkit which does everything you want straight out of the box. If that's what you need, I would suggest you look elsewhere. Instead, Cyberprobe is a set of flexible components which can be combined in many ways to manage a wide variety of packet inspection tasks. If you want to build custom network analytics there are many interfaces that make this straightforward.

The project maintains a number of components, including:

- **cyberprobe**, which collects data packets and forwards them a network stream protocol in real time. Packet collection can be targeted with IP addresses, CIDR ranges or full-take. Collected packets are tagged with a device identifier. **cyberprobe** can be integrated with Snort to allow dynamic targeting of IP addresses in response to a Snort rule hitting.
- **cybermon**, which receives collected packet streams, performs stateful processing and creates a stream of observations describing network events. The events can be consumed in many different ways e.g. the events can be delivered to a pub/sub system, or presented to a gRPC service. The event handling is implemented as a function written in Lua, so you can add your own custom event handling.
- a set of subscribers which can be used to do things with the captured data e.g. store to Elasticsearch, Cassandra or Gaffer.

Cyberprobe

The probe, **cyberprobe** has the following features:

- Can be tasked to collect packets from an interface and forward any which match a configurable address list. The address list can be individual IP addresses, CIDR ranges, or collect-all tasking ('0.0.0.0/0').
- Can be configured to receive Snort alerts. In this configuration, when an alert is received from Snort, the IP source address associated with the alert is dynamically targeted for a configurable period of time. This is useful for e.g. collecting data from any network actor who triggers a snort rule and is thus identified as a potential attacker.
- Can optionally offer a management API which allows remote interrogation of the state, and alteration of the configuration. This allows dynamic alteration of the targeting map, and integration with other systems.
- Can be configured to deliver on one of two standard stream protocols.
- Can insert a packet collection delay line of configurable duration. This can be useful e.g. with snort alert triggering to make sure all packets which trigger an alert are collected.

Cybermon

The monitor tool, `cybermon` has the following features:

- Analyses packets delivered in the ETSI stream protocol from one or more `cyberprobe` instances.
- Decodes a number of packet protocols to detect network events, which are delivered to your configuration in near-real-time.
- Decoded information is made available to user-configurable logic (written in Lua) to define how the decoded data is handled. Sample configuration files are provided to deliver to RabbitMQ in JSON, a gRPC endpoint, and deliver to a redis queue.
- Packet forgery techniques are included, which allow resetting TCP connections, and forging DNS responses. This can be invoked from your Lua configuration.
- Supports IP, TCP, UDP, ICMP, HTTP, DNS, SMTP, FTP, TLS and more.

The code is targeted at the Linux platform, although it is generic enough to be applicable to other UN*X-like platforms.

Subscribers

The event stream from `cybermon` can be presented to a Pulsar exchange in protobuf form, which can then be delivered to further analytics:

- `evs-alert` reports indicator hits in events to standard output.
- `evs-cassandra` loads events into Cassandra.
- `evs-detector` studies events for the presence of indicators. Events are annotated with indicator hits of any are observed.
- `evs-dump` dumps raw event JSON to standard output.
- `evs-elasticsearch` loads events into ElasticSearch.
- `evs-gaffer` loads network information into Gaffer (a graph database).
- `evs-geoip` looks up IP addresses in GeoIP and annotates events with location information.
- `evs-monitor` outputs event information to standard output.

Scaling

The architecture has support for AWS Traffic Mirroring, and supports cloud-scale deployments:

- Multiple `cyberprobe` instances can load-share across multiple `cybermon` instances behind a load-balancer.
- The event stream from `cybermon` can be delivered to a pub/sub system to distribute load and permit scale-up.

The easiest way to learn about the software is to follow our Quick Start tutorial.

Revision history

Cyberprobe release highlights:

- 2.5 Pulsar and protobuf support added, permits events from cybermon to be described in protobuf form, and delivered to a Pulsar pub/sub exchange. Renamed cybermon- subscribers to evs- (Event Stream).
- 2.4 `cybermon-detector` refactored to use FSM-based evaluation of boolean expressions.
- 2.3 `cyberprobe-cli` and control API reworked, protobuf and gRPC support. Amazon Linux support.
- 2.2 Changed cyberprobe configuration file to use JSON instead of XML. JSON is easier to integrate with automated processes.
- 2.0.5 Added VXLAN support to cybermon. This allows cybermon to receive the VXLAN protocol which is e.g. used by AWS Traffic Mirroring.
- 2.0 New simpler Lua API. Native JSON encoding boosts performance of JSON output by 500%.
- 1.13 Cybermon decodes for: TLS, GRE, ESP.
- 1.12.3 Brought subscribers and docker-compose files up-to-date.
- 1.11.1 Altered handling of 'origin' to make it more resilient.
- 1.11.0 Added 'origin' field to identify whether or not the triggering device caused an event.
- 1.10.0 Add RabbitMQ / AMQP 0.9.1 support for cybermon and subscribers.
- 1.8.4 Endace DAG package support added.
- 1.7.0 Gaffer subscriber brought up-to-date with Gaffer 1.0 API. GeoIP and IOC processor added to the subscriber model. Some unmaintained Lua code deprecated, as the subscriber model takes care of the functionality.
- 1.6.8 Numerous fixes. UUID generation uses a good seed. Elasticsearch loading fixed, Mac compilation fixed.
- 1.6.0 Changed ETSI sender so that packet streams are multiplexed over multiple TCP streams.
- 1.5.1 Unbounded queue internal to cybermon has a queue limit, to prevent unbounded growth.
- 1.5.0 Timestamp information at the time of packet capture in cyberprobe is now consistently passed through to cybermon and the Lua functions. The Lua API has undergone significant change as a result of passing through timing information.
- 1.0 Lua invocation mechanism has been replaced by a thread-safe queue function.

2 Obtaining the software

Deployment using containers

Deploying containers is by far the easiest way to get the software running. It is possible to deploy a complete software stack for data capture and analysis using Docker containers which requires the minimal amount of software installation. See Chapter 6 [A containerised processing system], page 31.

Debian / Ubuntu repository

We use GoCD to build the software, and regularly release packages in DEB and RPM form. Installing from the repository is the easiest way to install if you're not using containers.

In order to install, you need to add our signing key to your system:

```
wget -q -O- \
  https://cybermageddon.github.io/cyberprobe-release/cyberprobe.asc | \
  apt-key add -
```

We use this signing key:

```
pub  rsa4096 2020-06-05 [SC]
     E684 ECDC B4EA 9F64 DDD0 3D64 3C5A 9A8D 1389 8455
uid  [ultimate] Cyber MacGeddon <cybermageddon@gmail.com>
```

Once done you then add our repository to `/etc/apt/sources.list`.

For Debian Stretch, add:

```
deb https://cybermageddon.github.io/cyberprobe-release/debian \
  stretch main
```

For Ubuntu Bionic, add:

```
deb https://cybermageddon.github.io/cyberprobe-release/ubuntu \
  bionic main
```

For Ubuntu Disco, add:

```
deb https://cybermageddon.github.io/cyberprobe-release/ubuntu \
  disco main
```

Once added, the cyberprobe installation proceeds thus:

```
apt-get update
apt-get install cyberprobe
```

Fedora

To install using DNF, create file `/etc/yum.repos.d/cyberprobe.repo`:

```
[cyberprobe]
name=Cyberprobe
baseurl=https://cybermageddon.github.io/cyberprobe-release/fedora/$releasever/$basearch
gpgcheck=1
enabled=1
gpgkey=https://cybermageddon.github.io/cyberprobe-release/cyberprobe.asc
```

and then:

```
dnf install cyberprobe
```

We use this signing key:

```
pub  rsa4096 2020-06-05 [SC]
     E684 ECDC B4EA 9F64 DDD0  3D64 3C5A 9A8D 1389 8455
uid  [ultimate] Cyber MacGeddon <cybermagggedon@gmail.com>
```

Amazon Linux

To install using Yum create file `/etc/yum.repos.d/cyberprobe.repo`:

```
[cyberprobe]
name=Cyberprobe
baseurl=https://cybermagggedon.github.io/cyberprobe-release/amazon/$releasever/$basearch
gpgcheck=1
enabled=1
gpgkey=https://cybermagggedon.github.io/cyberprobe-release/cyberprobe.asc
```

and then:

```
yum install cyberprobe
```

We use this signing key:

```
pub  rsa4096 2020-06-05 [SC]
     E684 ECDC B4EA 9F64 DDD0  3D64 3C5A 9A8D 1389 8455
uid  [ultimate] Cyber MacGeddon <cybermagggedon@gmail.com>
```

Download packages

You can download packages manually; packages are currently available for Fedora, CentOS, Debian and Ubuntu. Downloads are available on the project page at <http://github.com/cybermagggedon/cyberprobe/releases>.

Fedora packages are installed using `dnf`:

```
sudo dnf install <package>
```

Debian and Ubuntu packages are installed using `dpkg`:

```
sudo dpkg -i <package>
```

If there are dependency errors e.g. because you don't have some dependencies installed, you can install them thus:

```
sudo apt-get install -f
```

Install from source

Note: on many platforms, installing a package just adds the "run time" part of the code. In order to be able to compile code against the run time, you need to install a separate "developers kit" package. On Fedora, for instance, both `libpcap` and `libpcap-devel` are needed in order to be able to build this code from source.

Note also that `lua` packages can be a little strange: sometimes the package will exist in your distribution, at other times you need to install a utility called `luarocks` to install the package.

Source downloads are available on the project page at <http://github.com/cybermageddon/cyberprobe/releases>, look for the `.tar.gz` file.

These files can be unwrapped, then configured:

```
tar xvfz cyberprobe-X.Y.tar.gz
cd cyberprobe-X.Y
./configure
make
sudo make install
```

`README.linux` provides some hints for Linux users. If installing on MacOS, read `README.mac`.

Installing from git

To checkout the latest code using git:

```
git clone https://github.com/cybermageddon/cyberprobe
```

To build, use:

```
autoreconf -fi
./configure
make
sudo make install
```

Powered by Github, project page is at <https://cybermageddon.github.io/cyberprobe-docs/>.

Docker repository

There are two Docker repositories containing the Cyberprobe distribution. See <http://hub.docker.com/r/cybermageddon/cyberprobe>.

- [docker.io/cybermageddon/cyberprobe](https://hub.docker.com/r/cybermageddon/cyberprobe)
- [docker.io/cybermageddon/cybermon](https://hub.docker.com/r/cybermageddon/cybermon)

The only difference is the default command which is executed on running the container. Here are some container invocations you may find useful:

- Run `cyberprobe`. You will need to create a configuration file and map it in to the container.

```
sudo docker -it --rm -v /etc/cyberprobe:/etc/cyberprobe_host \
  docker.io/cybermageddon/cyberprobe \
  cyberprobe /etc/cyberprobe_host/cyberprobe.fg
```

- Run `cybermon`. The `cybermon` container exposes port 9000.

```
sudo docker -it --rm -p 9000:9000 -v \
  --net=host --privileged --cap-add=NET_ADMIN \
  docker.io/cybermageddon/cybermon \
  cybermon -p 9000 -c /etc/cyberprobe/amqp-topic.lua
```

- Run `evs-cassandra`. You need to know the IP address of the host side of the Docker bridge network, and provide addresses of the Cassandra servers.

```
sudo docker -it --rm -v \
```

```
docker.io/cybermageddon/cybermon \  
evs-cassandra cyberprobe \  
10.142.146.6,10.142.146.8
```

Running cyberprobe in a container makes the deployment easier, but it needs to run with elevated privileges in order to sniff the network, which reduces some of the advantages of running it in a container.

Dependencies

The code doesn't have many dependencies. Exotic dependencies are:

- LUA - 5.1 or later.
- GCC C++ compiler and development support.
- libpcap.
- tcpdump - not needed to build the software, but we use it in the tutorial.
- ncurses, needed for the command line admin utility.
- readline, needed for the command line admin utility.
- For STIX support, libtaxii and stix are Python modules made available at <http://mitre.org> which can be downloaded using pip.
- Protobuf support, protobuf compiler and grpc for gRPC support (optional).

3 Quick start tutorial

3.1 Preparation

Build software

For installation, see Chapter 2 [Obtaining the software], page 5. There's a fair amount of development taking place in the git repository, so you probably want to get the a package, or use the latest release on the downloads page (<http://github.com/cybermageddon/cyberprobe/releases>).

The compilation process compiles the following commands:

cyberprobe

Packet capture.

cybermon Data analyser, analyses the data streams and reports events.

etsi-rcvr

Test decoder for ETSI format data.

cyberprobe-cli

Cyberprobe control command-line client.

evs-cassandra

Pub/sub subscriber, delivers events to Cassandra.

evs-elasticsearch

Pub/sub subscriber, delivers events to Elasticsearch.

evs-gaffer

Pub/sub subscriber, delivers events to Gaffer.

evs-geoip

Pub/sub subscriber, uses GeoIP to add location information to events, and then republishes them.

evs-detector

Pub/sub subscriber, looks for matches for STIX IOCs, adds IOC information to events, and then republishes them.

evs-dump Pub/sub subscriber, dumps out raw JSON messages.

evs-dump Pub/sub subscriber, alerts on matching IOCs.

If it installs / builds without errors, then it's time to start something up. If you have problems you can't resolve raise an issue at (<https://github.com/cybermageddon/cyberprobe/issues>).

Establish network parameters

The simplest way to use cyberprobe is to use it on a Linux workstation, or in a virtual machine. Maybe you're using a Linux desktop now now? If so, you could use it to capture all the data going to/from the internet. This will be a static configuration in order to keep things simple. We'll do dynamic tracking later.

In the next few steps, you'll use `cyberprobe` to capture some data, on your workstation, and stream it to `etsi-rcvr` so that you know it's working. But first, you'll need to collect some information about your configuration.

You need to know the name of the network interface you are using. The command `/sbin/ifconfig` will show you all the network interfaces your machine knows about. e.g.

```
lo: flags=73<UP,LOOPBACK,RUNNING> mtu 65536
    inet 127.0.0.1 netmask 255.0.0.0
    inet6 ::1 prefixlen 128 scopeid 0x10
    [etc.]

eth0: flags=4163<UP,BROADCAST,RUNNING,MULTICAST> mtu 1500
    inet 192.168.1.80 netmask 255.255.255.0
    inet6 fe80::a60:6eff:fe81:7a75 prefixlen 64
    [etc.]
```

The `lo` interface is a loopback interface, and isn't really on the network, so ignore that. It's an interface that gets packets going to `127.0.0.1` and makes sure they end up handled by your workstation. Your interface is quite likely to be called something like `eth0`. The other thing you need to know is the IP address of your workstation. The IP address is associated with an interface, so in the above example, I can see I have an IP address `192.168.1.80`.

Note: on some networks (like mine) the IP address is allocated dynamically. In my case, the IP address is allocated by the broadband router. If things aren't working as you expect, you should check your IP address to check your workstation hasn't been allocated a new, different address. In my case, I can tell the broadband router to permanently allocate a particular IP address to this workstation, so that it won't change.

3.2 Using cyberprobe

Starting cyberprobe with a configuration file

The source code contains a file `config.json` which is a good template for any configuration you're going to build. However, for the purpose of this discussion, let's start from scratch. In order to do anything useful, there are three essential elements to a cyberprobe configuration file: interfaces, targets and endpoints. The system won't do anything useful without those three configuration elements defined. Let's start with a very simple configuration.

Using your favourite text editor, create a text file, say `c.cfg` with the following contents:

```
{
  "interfaces": [
    { "interface": "eth0" }
  ]
}
```

Note: You should replace the `eth0` string with the name of your network interface. Remember? We discovered that when playing with the `ifconfig` command.

We're ready to roll. We need to run as a privileged user because `cyberprobe` captures data off the network interface. So, running as root, you need to locate the place where you compiled the code, and run `cyberprobe` giving it the name of the configuration file you just created:

```
cyberprobe c.cfg
```

If everything goes to plan, you should see the following output:

```
Capture on interface eth0 started.
```

If you see an error message, the obvious two things to check are:

- Did you name a network interface correctly? See `ifconfig` discussion above.
- Are you running as a privileged user?

If you see no output at all, check that your configuration file is correct.

Once you are seeing the "Capture on interface eth0" line, then you've achieved success in this step, and are ready to move on.

If you have everything working, there's one thing to note before moving on: `cyberprobe` treats a broken configuration file the same as an empty configuration file. With `cyberprobe` running, edit the configuration file, and delete the query ('?') prefix in the first line, so that it looks like this:

```
FIXME {
```

You've now broken the configuration file. It's not valid JSON any more, so the parsing fails. You should see this output from `cyberprobe`:

```
Capture on interface eth0 stopped.
```

If you repair the damage to the configuration file, everything will start working again. The lesson here is: If you find that `cyberprobe` won't recognise any resources, it's likely that your configuration file is invalid. Use a JSON parser to check that the file is valid if you're not getting the results you expect.

Adding a target

We have `cyberprobe` running, but it isn't doing anything useful. Remember, I said that a useful configuration consists of three minimal elements: interfaces, targets and endpoints? Well, currently we only have interfaces defined. That means that `cyberprobe` is capturing packets off of the network, but throwing them away.

Let's add a target. Edit the targets block of the configuration file. We need an entry describing the IP address of my workstation. Remember? We discovered that with the `ifconfig` command earlier? Instead of `192.168.1.80` use the IP address of your workstation.

```
{
  "interfaces": [
    { "interface": "eth0" }
  ],
  "targets": [
    {
```

```

        "address": "192.168.1.80",
        "device": "123456"
    }
]
}

```

If successful, you should see new output from `cyberprobe`:

```
Added target 192.168.1.80 -> 123456.
```

The target configuration allows specification of IPv4 and IPv6 addresses, and addresses can include a mask, which allows IP address matching to be applied in a wildcard configuration. See Section 9.2 [cyberprobe configuration], page 35,

At this step, we're capturing packets, spotting target addresses, but as there's no endpoint defined there's still nowhere to send the data. So, this is still a useless configuration. On to the next step...

Adding an endpoint

Adding an endpoint to the configuration file will define a place where the captured data is sent. Before adding an endpoint, let's make sure there's something ready to receive the data.

In a separate terminal window, navigate to the `cyberprobe` build, and run:

```
etsi-rcvr 10000 | tcpdump -n -r -
```

The `etsi-rcvr` program opens a TCP port listening on port 10000 for a stream of ETSI data, and on standard output, writes the IP packets it sees in PCAP format. The `tcpdump` command receives this PCAP data, and outputs packet summaries.

If that starts successfully, the next step is to plumb a connection from `cyberprobe` to `etsi-rcvr`.

Next, edit the configuration file, and edit the endpoints block to deliver packets to a local service on port 10000:

```

{
  "interfaces": [
    { "interface": "eth0" }
  ],
  "targets": [
    {
      "address": "192.168.1.80",
      "device": "123456"
    }
  ],
  "endpoints": [
    {
      "hostname": "localhost",
      "port": 10000,
      "transport": "tcp",
      "type": "etsi"
    }
  ]
}

```

```
]
}
```

If that worked, you should see `cyberprobe` start the endpoint:

```
Added endpoint localhost:10000 of type etsi
```

Hopefully you'll start to see some output from `tcpdump`...

Capturing data

At this step, `cyberprobe` should be forwarding an network traffic your workstation generates to the `tcpdump` command, so that you see data. Any average workstation is generating network traffic all the time, so you won't need to do anything. But if you see nothing, you can do something like, visit the Google home page in a browser on your workstation. You should see something like this pouring from the `tcpdump`.

```
18:54:24.376838 IP 192.168.1.80.54249 > 212.58.244.71.http: Flags [P.],
  seq 1:673, ack 1, win 115, options [nop,nop,TS val 129851063 ecr 33669
  55869], length 672
18:54:24.390768 IP 212.58.244.71.http > 192.168.1.80.54249: Flags [.]
,
  ack 673, win 124, options [nop,nop,TS val 3366955882 ecr 129851063], le
  ngth 0
18:54:24.392909 IP 212.58.244.71.http > 192.168.1.80.54249: Flags [P.],
  seq 1:1796, ack 673, win 124, options [nop,nop,TS val 3366955884 ecr 1
  29851063], length 1795
```

At this step, it's worth having a quick play with the reconnection mechanism. Stop and start `etsi-rcvr`, and you'll see that `cyberprobe` reconnects automatically:

```
ETSI LI connection to localhost:10000 failed.
Will reconnect...
ETSI LI connection to localhost:10000 established.
```

We don't guarantee zero data loss on a reconnect.

3.3 Management interface

At this step, we'll setup a control port, and use it modify the configuration of `cyberprobe`. First step is to modify the configuration file to include this line, just after the `<configuration>` line:

```
{
  "interfaces": [
    { "interface": "eth0" }
  ],
  "targets": [
    {
      "address": "192.168.1.80",
      "device": "123456"
    }
  ],
  "endpoints": [
    {
```

```

        "hostname": "localhost",
        "port": 10000,
        "transport": "tcp",
        "type": "etsi"
    }
],
"controls": [
    {
        "port": 8888,
        "username": "admin",
        "password": "mypassword"
    }
]
}

```

That declares that a management service needs to be run on port 8888. The authentication details are provided too. You should see this output from `cyberprobe`:

```
Starting control on port 8888
```

Good! Now need to connect and interrogate the targets list. The API is a simple text protocol with requests and responses encoded in JSON. The `cyberprobe-cli` command gives you an interactive CLI interface.

```
cyberprobe-cli localhost 8888
```

You are then prompted for a username and password:

```

$ cyberprobe-cli localhost 8888
Connected. You must authenticate.
User: admin
Password: *****
>

```

Press `TAB` to see command auto-completion.

```

> show endpoints
Hostname                Port    Type
-----                -
localhost              9000   etsi
localhost              9001   etsi
localhost              9002   nhis1.1
> add target my-machine4 ipv6 fe80:5551:4024:8196:8175::/40 dark-net
> show targets
Device                Class   Address                Mask
-----                -
my-machine            ipv4   0.0.0.0                /0
my-machine2           ipv4   10.0.0.0                /8
my-machine4           ipv6   fe80:5551:4000::       /40
my-machine3           ipv6   fe80:4124:5696::       /48
> remove target my-machine4 ipv6 fe80:5551:4024:8196:8175::/40 dark-net
> add interface vxlan:8124 0.5 not port 9000
> show interfaces

```

Interface	Delay	Filter
-----	-----	-----
vxlan:4789	0.5	not port 10001 and not port 10002
vxlan:4790	0.3	
vxlan:8124	0.5	not port 9000

The interface isn't pretty, but you get the idea. You can change almost everything that you can manage by changing the configuration file.

Note: The the management interface changes the active state of `cyberprobe` but it doesn't change the configuration file. So, configuration changes made through the management interface are 'lost' when you restart `cyberprobe`.

Note also that you may get some weird results if you use the configuration file AND the control interface to manage the same resources, so you probably don't want to do that.

See Section 9.3 [`cyberprobe-cli` invocation], page 37.

3.4 Integration with snort

In this step, we'll add the excellent IDS, Snort to the mix. If you don't know Snort, it scans network traffic for patterns, and can take various actions when those patterns are discovered. It is typically used to detect network attacks, and the Snort folks maintain a huge collection of patterns that will identify known network attacks. The Snort team maintain the project at <http://www.snort.org>.

If you want to try out the Snort integration, you need to head over to the Snort home page, download and install Snort. Or install the appropriate package with your distribution.

Once you have it installed, to simplify things, you'll want to put a rule in place that will definitely identify things on your network. The easiest way is to add a local rule that identifies your workstation. First of all, you'll want to make sure your Snort configuration file (probably `/etc/snort/snort.conf`) loads a local rules file. So, it should contain something like this:

```
# site specific rules
include $RULE_PATH/local.rules
```

Then, to identify your workstation, add a rule like this to your local rules file (probably `/etc/snort/rules/local.rules`):

```
alert tcp 192.168.1.80 any -> any 80 (msg:"Web";
  classtype:misc-activity;sid:200; rev:1;)
```

`cyberprobe` itself needs to be configured to receive Snort alerts. You do that by adding a block to the configuration file at the top level:

```
{
  ...
  "snort-alerters": [
    {
      "path": "/var/log/snort/snort_alert",
      "duration": 60
    }
  ]
  ...
}
```

```
}

```

That says, Snort alerts will result in dynamic collection of data for 60 seconds from identification. While you're in the configuration file, you can remove the static IP address target line. Make sure the targets block is empty or removed from the configuration:

```
{
...
  "targets": [],
...
}
```

cyberprobe should respond:

```
Removed target 192.168.1.80 -> 123456.
Start snort alerter on /var/log/snort/snort_alert
```

Now I can run Snort in IDS mode. Snort needs to run as 'root':

```
snort -i eth0 -A unsock -N -l /var/log/snort/ -c /etc/snort/snort.conf
```

Thanks to our Snort rule, when our workstation generates network data, Snort will detect it, trigger our rule, and alert `cyberprobe`. You should see `cyberprobe` say:

```
Hit on signature ID 200, targeting 192.168.1.80
```

Also, once the rule is triggered, you should see evidence of packet data from the `tcpdump` command, as before. `cyberprobe` causes the targeting to time out after a period of time. If further alerts are seen, the targeting lifetime is targeted. If no further alerts are seen the IP address targeting is deleted. If you can convince your workstation to stop creating network data, by e.g. not using it for a minute or so, then you should see the rule time out:

```
Stopped targeting on 192.168.1.80
```

In practice this may be harder than you think, as workstations generate network traffic all the time. You may have to turn off your email clients and close the web browser. Your attempt to silence your workstation may be further thwarted by the operating system checking for patches without you knowing.

Introducing a delay

Your Snort integration suffers from a particular problem now. The time taken for Snort to inspect some packets, generate an alert and for `cyberprobe` to get the IP address targeted is not zero. It is hard to measure, but it is going to be a significant chunk of a millisecond. The problem is that by the time `cyberprobe` is targeting the IP address, the network attacker's packets have long gone. The result is, that while `cyberprobe` is now targeting the attacker, it won't capture the original network attack.

Our solution is to introduce a packet delay in `cyberprobe`. The packets entering `cyberprobe` are kept in a time-delay queue and are processed once that delay expires. You can configure a delay, by putting the delay attribute in an interface specification. e.g.

```
...
  "interfaces": [
    { "interface": "eth0", "delay": 0.2 }
  ]
```

...

0.2 second should be plenty enough. You should be able to see this delay in action: When you generate network traffic, you should be able to see the delay between network activity taking place, and the corresponding burst of activity from tcpdump.

At this point, you've completed the guided tour of `cyberprobe`, the packet capture tool. If that's all you need, the rest of the tutorial will probably have less interest to you: In the following steps, we'll start to analyse and act on the captured data.

3.5 Using cybermon

Introducing cybermon

The previous 9 steps have all been about `cyberprobe`. If you've got this far successfully, you pretty much know all there is to know about `cyberprobe`. It is time to start doing something more useful with all that data you are capturing. In this step we'll start up `cybermon` and look at the data.

Remember that `etsi-rcvr` command you started in step [Adding an endpoint], page 12? Stop that, and start `cybermon`. Two arguments are needed: A TCP port number to receive the data on, and a configuration which tells it what to do. A number of configuration files are bundled in with the source code, there should be a basic one called `monitor.lua` which is now installed in the `etc` directory, depending on where you installed the software:

```
cybermon -p 10000 -c /usr/local/etc/cyberprobe/monitor.lua
```

Now when you generate network traffic, some of the traffic will be presented in a reasonably intelligent form. For example, I do a naming service lookup for `www.google.com`...

```
host -t a www.slashdot.org
```

The DNS protocol is parsed, and presented in a human readable form. I can see the request, and the response:

```
SNORTc0a80150: 192.168.1.80:54633 -> 192.168.1.1:53. DNS query
Query: www.slashdot.org
```

```
SNORTc0a80150: 192.168.1.1:53 -> 192.168.1.80:54633. DNS response
Query: www.slashdot.org
Answer: www.slashdot.org -> 216.34.181.48
```

I see the query travelling from my workstation to the broadband router, and then the response from the broadband router contains an answer field mapping the name to an address. HTTP protocols are also decoded. Get the Slashdot home page...

```
wget -O- 'http://www.slashdot.org/'
```

...and amongst all the other stuff, you see the HTTP request and response...

```
SNORTc0a80150: 192.168.1.80:34284 -> 216.34.181.45:80. HTTP GET request
URL /
Connection: Keep-Alive
User-Agent: Wget/1.14 (linux-gnu)
Host: slashdot.org
Accept: */*
```

```
SNORTc0a80150: 216.34.181.45:80 -> 192.168.1.80:34284. HTTP response 200
OK
```

```
URL http://slashdot.org/
Connection: keep-alive
Content-Length: 113468
Date: Mon, 26 Aug 2013 13:13:25 GMT
Age: 17
X-Varnish: 1493567531 1493567417
X-XRDS-Location: http://slashdot.org/slashdot.xrds
Cache-Control: no-cache
Vary: Accept-Encoding
SLASH_LOG_DATA: shtml
Pragma: no-cache
Content-Type: text/html; charset=utf-8
Server: Apache/2.2.3 (CentOS)
```

Trying other configuration files

In the previous step, you started `cybermon` with the `monitor.lua` configuration file.

Configuration file `json.lua` causes `cybermon` to output the events as JSON objects.

```
cybermon -p 10000 -c /usr/local/etc/cyberprobe/json.lua
```

The `quiet.lua` configuration file does nothing. It may be a good place to start hacking your own configuration file. Which is exactly what we'll do in the next step.

3.6 Writing your own configuration file

Now, take a copy of the `quiet.lua` configuration file, and have a look at it. It is a Lua module which defines a minimum of one function, `'event'`, which is called when events occur. LUA is a lightweight scripting language which is really good as a configuration language. This function is called when a TCP connection is made:

```
observer.event = function(e)
end
```

Let's get hacking! The header parameter is a LUA table which contains key/value pairs from the header. The `url` parameter contains the full URL of the response. The `body` parameter contains the payload body as an empty string. Let's start simple:

```
observer.event = function(e)
  if e.action == "http_response" then
    print(url)
  end
end
```

Then run that up...

```
cybermon -p 10000 -c my.lua
```

Now, do some web browsing, and you should see a list of URLs flying past. Each web page typically consists of several HTTP requests, but you should be able to see the URLs associated with all of the web pages you visit. Let's start that up a little more:

```

-- This function is called when an HTTP response is observed.
observer.event = function(e)

    if e.action == "http_response" then

        -- Take first 40 characters of URL
        local u = url:sub(1,40)

        -- Get Content-Type (first 20 characters)
        local ct
        ct = ""
        for key, value in pairs(header) do
            if key:lower() == "content-type" then
                ct = value:sub(1,20)
            end
        end

        io.write(string.format("%-40s %-20s %d\n", u, ct, #body))

    end

end

```

That basically outputs three columns: The URL (truncated to 40 characters), the body content type (truncated to 20 characters) and the HTTP response payload length. Here's what I get from visiting Slashdot:

```

http://widget-cdn.rpxnow.com/manifest/sh text/javascript;char 42980
http://slashdot.org/ text/html; charset=u 40105
http://ad.doubleclick.net/adj/ostg.slash text/javascript; cha 5625
http://pagead2.googlesyndication.com/pag application/x-shockw 33347
http://ad.doubleclick.net/adj/ostg.slash text/javascript; cha 540
http://ad.doubleclick.net/adj/ostg.slash text/javascript; cha 42
http://ad.doubleclick.net/adj/ostg.slash text/javascript; cha 452
http://pagead2.googlesyndication.com/pag 0

```

Forging a TCP reset

So far, this has just been monitoring. It's time to add data to the network! From the LUA functions, there are a couple of functions available which allow you to put some packets back onto the network.

But first... there's a problem. You remember in step 9, we added a delay? That's not going to work with packet forgery, because by the time we've forged a packet and sent it on to the network, it's too late. So, we need to change our interface back so that there's no delay on the interface. That means, we're monitoring network data, but we'll miss the original attack which triggered a Snort alert.

```

...
"interfaces": [

```

```

        { "interface": "eth0", "delay": 0.0 }
    ],
    ...

```

Once you have this code working, you might be able to mess with the delay parameter to see if you can pick a low-latency value that works for you. On my network, the value 0.02 is low enough to allow a response to allow packet forgery to work. Any higher, and the forged packets are too late to beat the real packets.

The LUA interface passes a context variable to many of the LUA functions, which gives access to `cybermon` information and the packet forgery functions. In this step, we're going to forge a TCP reset on any connections which are from or to port 80. Hack the configuration file:

```

observer.event = function(e)

    if e.action == "connected_up" then

        -- Get TCP ports.
        local cls, src_addr, dest_addr
        cls, src_addr = e.context:get_src_addr()
        cls, dest_addr = e.context:get_dest_addr()

        -- check if it is port 80.
        if not((src_addr == "80") or (dest_addr == "80")) then
            -- Ignore non-HTTP traffic
            return
        end

        -- TCP reset
        print("Reset on HTTP connection.")
        e.context:forge_tcp_reset(context)

    end

end

```

Now before we go any further, `cybermon` needs to run as root in order to use either of the packet forgery functions. Packet forgery needs access to the raw IP socket layer, which is a privileged operation. Start that up:

```
sudo cybermon -p 10000 -c my.lua
```

Now start web browsing, and you should see a bunch of "Reset on HTTP connection" messages. Also, you'll see a page saying "The connection was reset" in your web browser. That's a fairly anti-social configuration to run on any network. See the `forge-reset.lua` example for a more useful configuration. It disrupts network traffic going to/from an SSH server which isn't from your administration workstation.

On any network with an SSH service open to the outside world, you might want to use firewall rules to prevent access to the SSH service from addresses outside of your network, but you could use `cybermon` as a belt-and-braces protection mechanism.

Another example is where you know the user community on your network is being targeted by phishing emails. Your first step is to try to get the phishing emails out of their inboxes, getting your email provider to filter the attacks. But a backup attack would be to make sure your users can't get to the phisher's web site. The event function allows us to reset requests going to a particular web site.

```
observer.event = function (e)

  if e.action == "http_request" then

    if e.header["Host"] == "example.org" then
      print("Reset on HTTP request")
      context:forge_tcp_reset(context)
    end

    if e.header["Host"] == "www.example.org" then
      print("Reset on HTTP request")
      context:forge_tcp_reset(context)
    end

  end

end

end
```

Forging a DNS response

In this step, we'll detect a particular DNS request, and forge a response. First of all, you'll need to familiarise yourself with host which is a useful DNS test tool. e.g.

```
$ host -t a example.org
example.org has address 93.184.216.119
```

The `example.org` name has been resolved to a particular IP address. Let's hack the DNS request function in `my.lua`:

```
-- This function is called when a DNS message is observed.
local observer = {}

observer.event = function(e)
  if e.action ~= "dns_message" then
    return
  end

  if e.header.qr == 0 and #e.queries == 1 and e.queries[1].name == "example.org"
    and e.queries[1].type == 1 and e.queries[1].class == 1 then

    -- Send a fake response

    -- Set query/response flag to 'response'
    header = e.header
```

```

header.qr = 1
header.ancount = 2

-- Two answers, give example.org 2 alternative IP addresses.
answers = {}
answers[1] = {}
answers[1].name = "example.org"
answers[1].type = 1
answers[1].class = 1
answers[1].rdaddress = "1.2.3.4"
answers[2] = {}
answers[2].name = "example.org"
answers[2].type = 1
answers[2].class = 1
answers[2].rdaddress = "5.6.7.8"

-- Two answers
e.header.ancount = 2

io.write("Forging DNS response!\n")

e.context:forge_dns_response(header, e.queries, answers, {}, {})

end

end

-- Return the table
return observer

```

So, this example, checks that the query is one we want to mess with. If it is, we turn the query structures into response structures, and hand them back to `cybermon` to do a forgery. The above example forges the address 1.2.3.4. Start up `cybermon` with the script:

```
cybermon -p 10000 -c my.lua
```

If everything is working your host command will show a different result:

```
$ host -t a example.org
example.org has address 1.2.3.4
```

DNS forgery has applications in blocking access to a phishers resources on the internet, you might want to redirect your users to an address which is inside your network.

The Section 9.9 [cybermon configuration], page 48, documentation details the LUA interface in detail if you want to find out what else you can do in your LUA code.

3.7 Visualisation

Storing observations

Now we need somewhere to store the observations which `cybermon` discovers. There are many candidates for a storage repository, but my favourite for this sort of scenario is the excellent `ElasticSearch` (<http://www.elasticsearch.org/>). It is flexible, offers a huge amount of functionality, and is incredibly simple to interface with, thanks to its JSON API. So, your next action is to head over to the download page (<http://www.elasticsearch.org/download/>) and get hold of the latest version. I'm using version 7.0 to build this tutorial but the `ElasticSearch` API has proven hugely stable, so should work with the latest.

The easiest way to run `ElasticSearch` is as a Docker container, although you could download and run the distribution.

```
docker run --name elasticsearch -p 9200:9200 \
  elasticsearch:7.0
```

One brilliant thing about `ElasticSearch` is that it needs almost no configuration to get an instance started. You will need to make one configuration change to `ElasticSearch` if there are other instances running on your network: you need need to change `cluster.name` to some unique string in `config/elasticsearch.yml`, otherwise your `ElasticSearch` instance might join another cluster on your network, which could complicate things.

You can check you have `ElasticSearch` up and running using a command such as this:

```
wget -q -O- http://localhost:9200
```

The response will look something like this:

```
{
  "name" : "gAbVXGZ",
  "cluster_name" : "docker-cluster",
  "cluster_uuid" : "TPZLBGYnTNqe0-LVLiF6yw",
  "version" : {
    "number" : "7.0.0",
    "build_hash" : "bd92e7f",
    "build_date" : "2017-12-17T20:23:25.338Z",
    "build_snapshot" : false,
    "lucene_version" : "7.1.0",
    "minimum_wire_compatibility_version" : "5.6.0",
    "minimum_index_compatibility_version" : "5.0.0"
  },
  "tagline" : "You Know, for Search"
}
```

Once `ElasticSearch` is running, you can get `cybermon` to load observations into it. Before we do that, need `Pulsar` to provide the pub/sub infrastructure:

```
docker run -it \
  --name pubsub \
  -p 6650:6650 \
  -p 8080:8080 \
  apache/pulsar:2.5.2 \
  bin/pulsar standalone
```

Next we need to run two commands. Firstly, `cybermon` is run to output events on a Pulsar pub/sub exchange.

```
cybermon -p 10000 -c /usr/local/etc/cyberprobe/pulsar.lua
```

While that's running, we can start the ElasticSearch loader:

```
evs-elasticsearch cyberprobe
```

After some network data has been observed, you should be able to see results loaded into ElasticSearch using the following command:

```
es=localhost:9200
curl -s -XPOST \
  "http://$es/cyberprobe/_search?pretty=true" -d '
{
  "query" : {
    "match_all": {}
  }
}
,
```

You should see some stuff which looks like data scrolling past on the screen. If your response looks like the following result, that's not so good, as it means there are no results. See `hits.total`? Zero means no results.

```
{
  "took" : 1,
  "timed_out" : false,
  "_shards" : {
    "total" : 5,
    "successful" : 5,
    "failed" : 0
  },
  "hits" : {
    "total" : 0,
    "max_score" : null,
    "hits" : [ ]
  }
}
```

If you see a lot of information scrolling past on the screen, that's good.

`evs-elasticsearch` maps the `cybermon` observations into a form which is appropriate to store in ElasticSearch.

Visualising observations

Having loaded the observations into ElasticSearch, it's easy to do some visualisation with Kibana. Kibana is a brilliant, user-configurable dashboard package designed to sit on ElasticSearch. The dashboard runs in your browser.

First thing to do is to run up a Kibana container. Kibana is made by the ElasticSearch people, download page is at <http://www.elasticsearch.co/downloads/kibana>.

Run a Kibana container:

```
docker run --name kibana \
  -e ELASTICSEARCH_URL=http://elasticsearch:9200/ -p 5601:5601 \
  --link elasticsearch:elasticsearch \
  kibana:7.0
```

Kibana starts on port 5601, so point your browser at e.g. `http://localhost:5601` and hopefully you see Kibana's "Welcome to Kibana" screen.

Read the Kibana tutorial and start playing with the data. First thing you need to do is create a `cyberprobe` index with the time field `time`. Then go to the Visualize tab to see raw data.

Once you have data loading into Elasticsearch, you may want to install our basic dashboards. These are installed at:

```
/usr/local/share/doc/cyberprobe/kibana-dashboards.json
```

3.8 Threat indicators

Cyberprobe includes a subscriber which applies indicators to events. When an event matches an indicator, information about the indicator is tagged into the event.

Indicator support is present in the `evs-detector` subscriber which reads indicators from a JSON file.

Indicator files

The installation bundle includes a file containing some sample indicators, search for `indicators.json`, which may be installed at `/usr/local/share/doc/cyberprobe`.

Deploying threat information to cybermon

To run using your existing processing pipeline, stop any running `cybermon` and `evs-elasticsearch` processes. Then run `cybermon` to publish to a topic on Pulsar:

```
cybermon -p 10000 -c /usr/local/etc/cyberprobe/pulsar.lua
```

Next run `cyberprobe-detector` to apply indicator rules. By default, this will subscribe to `'cyberprobe'` and publish to `'ioc'`:

```
env INDICATORS=/path/to/indicators.json evs-detector \
  cyberprobe ioc
```

Finally, in order to look at the output, we need to subscribe to `'ioc'`:

```
evs-dump ioc
```

If you have `jq` installed, this will make it easier to see when indicators hit:

```
evs-dump ioc | jq --unbuffered .indicators
```

This activity should trigger a threat:

```
wget -q -O- http://www.malware.org/malware.dat
```

If this works, you should see the following output:

```
[
  {
```

```
    "description": "URL of a page serving malware",
    "category": "malware",
    "author": "someone@example.com",
    "source": "id:3245edd9-e0f3-4982-9406-fbf93b874555",
    "type": "url",
    "value": "http://malware.org/malware.dat"
  }
]
```

This hits on a number of threat indicators. The hostname `www.malware.com` is present in a threat indicator, and it is detected in the HTTP request, and both the DNS query and response. Also, the URL `http://www.malware.org/malware.dat` is in a threat indicator and it is detected in both the HTTP request and response.

`evs-detector` updates its state if the JSON configuration file has changed.

If you want to load the output of `evs-detector` into ElasticSearch, you can, but you need to subscribe to `'ioc'`:

```
evs-elasticsearch ioc
```

This results in indicator hit information being loaded into ES.

For more information on indicators, see Section 9.18 [`evs-detector` invocation], page 79, and Section 9.19 [Cyberprobe indicator format], page 79.

See <https://github.com/cybermagedon/threat-exchanges> for code which creates indicator sets from threat exchanges.

Conclusion

All done, I hope you enjoyed the tutorial! Any comments on the software, or tutorial itself are very welcome! Positive, or negative, we want to hear how you found the experience.

4 Running cyberprobe/cybermon at boot time

The `cyberprobe` and `cybermon` utilities are used as a pair to analyse network data. The `cyberprobe` component is used to capture data and forward to `cybermon`. When running on a network, you can decide to run several `cyberprobe` deployments into a single `cybermon`. Or run a `cybermon` process everywhere you run a `cyberprobe`.

Once you have decided your checklist, your setup checklist for using `cyberprobe` and `cybermon` consists of:

- Install the software, see Chapter 2 [Obtaining the software], page 5.
- If you are going to run `cyberprobe`, provide the appropriate configuration in file `/usr/local/etc/cyberprobe.cfg`. The standard installation will install a template at this location. See Section 9.2 [`cyberprobe` configuration], page 35, on managing this configuration file. Make sure that the configuration file includes the delivery address of the appropriate `cybermon`.
- If you are going to run `cybermon`, provide the appropriate configuration in file `/usr/local/etc/cyberprobe/cybermon.lua`.

The standard installation does not create a file at this location, and you should create one. You can copy an example from the `/usr/local/etc/cyberprobe` directory. Use `/usr/local/etc/cyberprobe/amqp-topic.lua` if you want to use pub/sub delivery. See Section 9.9 [`cybermon` configuration], page 48, for more information on constructing the configuration file. See Section 9.10 [`cybermon` example configurations], page 64, for descriptions of the example configuration files.

- The installation installs appropriate `systemd` configuration, and you can enable boot-time starting of `cyberprobe` or `cybermon` by using either or both of these commands:

```
systemctl enable cyberprobe
systemctl enable cybermon
```

Once enabled, you can reboot, or immediately start the processes using either or both of these commands:

```
systemctl start cyberprobe
systemctl start cybermon
```

5 The pub/sub infrastructure

5.1 Pub/sub overview

Events from `cybermon` can be delivered to a pub/sub mechanism which allows subscribers to connect and disconnect without disrupting delivery to other subscribers. The pub/sub mechanism used is Pulsar, which is a simple high-performance, distributed exchange.

In order to use this mechanism, you need to ensure you have configured `cybermon` appropriately. This is normally done by using the `pulsar.lua` configuration file. Copy to `cybermon.lua` in directory `/usr/local/etc/cyberprobe/` to use this by default with standard system startup of `cybermon`. Alternatively, `cybermon` can be manually invoked, specifying the `pulsar.lua` pathname on the command line.

Once running, `cybermon` will publish all events to Pulsar’s ‘`cyberprobe`’ topic.

Pulsar allows subscribers to be started and stopped without affecting the delivery of events to other receivers. That is, you can start `cybermon` with no subscribers, discarding data, and introduce subscribers later.

For more advanced processing scenarios, multiple pub/sub components can be chained. e.g.

- `cybermon` can be executed with `pulsar` to publish events to Pulsar topic ‘`cyberprobe`’.
- `evs-geoip` can subscribe to ‘`cyberprobe`’, and push events containing information to ‘`geo`’.
- `evs-detector` can do lookup for IOCs and push events with IOC detection information to ‘`ioc`’.
- `evs-elasticsearch` can subscribe to ‘`ioc`’ and write events to ElasticSearch.

5.2 The Cassandra subscriber

Note: The Cassandra subscriber doesn’t do much useful. I recommend skipping this bit.

This subscriber writes data to a Cassandra store in a schema useful for graph analysis.

The schema is experimental, but see <https://github.com/cybermageddon/cassandra-redland> for the tooling I’m using.

On the command-line you need to tell the subscriber the location of the Cassandra contact points e.g.

```
evs-cassandra ioc cas1,cas2,cas3
```

See Section 9.16 [`evs-cassandra` invocation], page 78.

5.3 The ElasticSearch subscriber

This subscriber extracts events from pub/sub and formats them for delivery to ElasticSearch. The only piece of information you need is the ElasticSearch base URI, which is used as a command-line parameter e.g.

```
evs-elasticsearch ioc http://es-host1:9200
```

See Section 9.14 [`evs-elasticsearch` invocation], page 78.

5.4 The Gaffer subscriber

About Gaffer

Gaffer is a graph database built on top of Accumulo, Zookeeper and Hadoop. This subscriber writes IP, TCP and UDP communication information into the graph. If you want to use this, get familiar with Gaffer. Gaffer development is hosted on Github at <https://github.com/gchq/Gaffer>, and I maintain Gaffer containers here:

<https://hub.docker.com/r/cybermageddon/wildfly-gaffer/>
Gaffer component, provides REST interface running in a Wildfly container.

<https://hub.docker.com/r/cybermageddon/accumulo-gaffer/>
Accumulo component, with added Gaffer operator library which is necessary to be able to use Gaffer on Accumulo.

<https://hub.docker.com/r/cybermageddon/zookeeper/>
Zookeeper container, which is required by Accumulo.

<https://hub.docker.com/r/cybermageddon/hadoop/>
Hadoop container, which is required by Accumulo.

Running Gaffer

To get started, you can run a Gaffer system by launching with the minimal set of containers:

```
GAFFER_VERSION=1.1.2

# Run Hadoop
docker run -d --name hadoop cybermageddon/hadoop:2.8.1

# Run Zookeeper
docker run -d --name zookeeper \
    cybermageddon/zookeeper:3.4.10b

# Run Accumulo
docker run -d --name accumulo --link zookeeper:zookeeper \
    --link hadoop:hadoop \
    cybermageddon/accumulo-gaffer:${GAFFER_VERSION}

# Run Wildfly, exposing port 8080.
docker run -d --name wildfly --link zookeeper:zookeeper \
    --link hadoop:hadoop --link accumulo:accumulo \
    -p 8080:8080 \
    cybermageddon/wildfly-gaffer:${GAFFER_VERSION}
```

The Gaffer/Wildfly component takes about 30 seconds to bed in. Once working, you can check the status of Gaffer by interacting with the REST API. This command should return the Graph schema, which is a JSON object:

```
wget -q -O- http://localhost:8080/rest/v1/graph/schema
```

You can fetch the entire graph using this command. Initially, the graph will be empty. This command may take a long while to run once the graph is loaded with loads of data:

```
wget -q -O- --header 'Content-Type: application/json' \  
  --post-data '  
  {"class": "uk.gov.gchq.gaffer.operation.impl.get.GetAllElements"}  
  ' http://localhost:8080/rest/v2/graph/operations/execute
```

Linking to cybermon

On the command-line you need to tell the subscriber the location of the Gaffer REST API. e.g.

```
evs-gaffer ioc \  
  http://localhost:8080/rest/v1
```

See Section 9.15 [evs-gaffer invocation], page 78.

5.5 The debug monitor subscriber

The `evs-monitor` subscriber is a subscriber which takes events and writes human-readable output on standard output. This is a useful means to verify that `cyberprobe`, `cybermon` and `pub/sub` are configured correctly.

See Section 9.13 [evs-monitor invocation], page 77.

6 A containerised processing system

Cybermon, Gaffer, ElasticSearch

The `cybermon`, subscriber components and data stores can easily be deployed in containers to form a scalable processing system.

To illustrate this in use, we distribute a Docker Compose configuration which can be used to start:

- A `cybermon`, listening on port 9000.
- A `evs-geoip` container, adding GeoIP information to events.
- A `evs-detector` container, adding IOC information to events from a sample STIX data set.
- A `evs-elasticsearch` container, to load information into ElasticSearch.
- A `evs-gaffer` container, to load information into Gaffer.
- An `elasticsearch` container to store events.
- A `kibana` container to store events.
- A Gaffer cluster consisting of Hadoop, Zookeeper, Accumulo and Gaffer containers.

You can see the Docker Compose configuration at the path:

```
/usr/local/share/doc/cyberprobe/docker-compose.yml
```

In order to invoke this run:

```
cd /usr/local/share/doc/cyberprobe/
docker-compose up
```

No data is stored persistently - you can change how this works by changing the `docker-compose.yml` file. It takes about a minute to settle down, at which point, you need to generate data using `cyberprobe` and send to port 9000.

You can connect to the Kibana instance on port 5601. The first thing you will need to do is to go to the Management > Index Patterns dialogue, and create an index pattern for index 'cyberprobe', with time specified in the 'time' field.

You may want to install our data dashboards, using Management > Saved Objects and press the Import button. The dashboard file is installed at:

```
/usr/local/share/doc/cyberprobe/kibana-dashboards.json
```

ElasticSearch bails out unless 'vm.max_map_count' setting is right. If you have problems, try:

```
sudo sysctl vm.max_map_count=512000
```

Snort, Cyberprobe, Cybermon, Gaffer, ElasticSearch

There is a second configuration which adds Snort and Cyberprobe to the deployment. This accesses the host network interface by providing host network access to the `cyberprobe` and `snort` containers. The network interface name is specified in the `cyberprobe.cfg` file for `cyberprobe` and the `docker-compose-cp-snort.yml` file for `snort` so you will need to edit accordingly.

```
cd /usr/local/share/doc/cyberprobe/
```

```
docker-compose \  
-f /usr/local/share/doc/cyberprobe/docker-compose-cp-snort.yml up
```

The configuration results in trigger packet acquisition as soon as any port 80 or port 11111 data is observed. e.g.

```
wget -q -O- http://www.example.org/
```

7 Integrating with AWS Traffic Mirroring

Overview

AWS allows you to mirror network traversing a network interface (ENI) to another ENI, essentially providing the equivalent of an Ethernet tap in a data centre. Traffic Mirroring allows you to select network interfaces or NLBs for traffic mirroring. Filters can be applied to select the subset of traffic which will be mirrored, and a target interface allows you to specify an ENI or load-balancer to receive the data. Data is delivered in VXLAN format, essentially, Ethernet frames wrapped in an 8-byte header. These frames are delivered over UDP to port 4789.

Cyberprobe implementation

Cyberprobe provides two ways to integrate with AWS Traffic Mirroring:

- **cyberprobe** implements VXLAN reception. If an interface is defined whose name has a `vxlan:PORT` form, then a VXLAN receiver is started on the specified UDP port number. For AWS traffic mirroring, delivery is on port 4789, so the interface name `vxlan:4789` would be used.
- **cybermon** implements VXLAN reception with the `-V` option allowing a port to be specified. Events produced from a VXLAN feed have the device ID set to the string 'VNI' plus the VNI identifier in decimal.

Using VXLAN support in **cyberprobe** provides more flexibility, as this allows delay line and filter commands to be used. Also, IP addresses can be mapped to device IDs.

Using VXLAN support in **cybermon** means that **cyberprobe** does not need to be used, and provides for a simpler architecture.

8 Endace DAG

`cyberprobe` includes support for Endace DAG. This is presently not distributed. If you compile `cyberprobe` on a host which has the DAG library (`libdag`) installed, it will be detected at the `configure` step.

If DAG support is compiled in, then the DAG devices can be referenced in the `cyberprobe.cfg` file using the prefix ‘`dag`’ plus the card number e.g.

```
...
"interfaces": [
  { "interface": "dag0" }
]
...
```

To use DAG devices, you need to load DAG firmware, and set all appropriate card options using `dagload` and `dagconfig` prior to starting `cyberprobe`.

9 Reference

9.1 cyberprobe invocation

cyberprobe is a network monitor which collects packets which match an IP address list. The packets collected are streamed using network streaming protocols. The IP address match list can be statically configured (in a configuration file), can be dynamically changed using a management interface, or can be dynamically changed as a result of snort alerts. Synopsis:

```
cyberprobe configuration-file
```

- *configuration-file* is the name of a JSON configuration file. See Section 9.2 [cyberprobe configuration], page 35.

cyberprobe executes indefinitely - to end the program, a signal should be sent. e.g.

```
killall cyberprobe
```

9.2 cyberprobe configuration

The configuration file is re-read when it changes, and changes are immediately actioned.

Sample configuration:

```
{
  "interfaces": [
    {
      "interface": "eth0",
      "filter": "not port 10001 and not port 10002",
      "delay": 0.5
    },
    {
      "interface": "eth1"
    }
  ],
  "targets": [
    { "address": "192.168.1.1", "device": "sam-iphone" },
    { "address": "192.168.1.2", "device": "fred-android" },
    { "address": "10.2.0.0/16", "device": "lisa-mac" },
    { "address": "10.1.1.0", "device": "suzie-mac" },
    { "address": "10.1.1.2", "device": "suzie-android" },
    { "address": "10.1.1.3", "device": "suzie-iphone" },
    { "address": "10.1.1.4", "device": "imogen-pc" },
    { "address": "10.1.1.5", "device": "imogen-pc" },
    { "address": "10.1.1.6", "device": "imogen-pc" },
    { "address": "10.1.1.7", "device": "imogen-ipad" },
    { "address": "10.1.1.8", "device": "imogen-android" },
    { "address": "10.1.1.9", "device": "imogen-android" },
    { "address": "10.1.1.10", "device": "will-tablet" },
    { "address": "aaaa:bbbb:cccc:dddd::4:5:6", "class": "ipv6",
      "device": "sam-pc" },
  ]
}
```

```

        { "address": "aaaa:bbbb:cccc::/48", class: "ipv6",
          "device": "sam-pc" }
    ],

    "endpoints": [
        {
            "hostname": "monitor1",
            "port": 10001,
            "type": "nhis1.1"
        },
        {
            "hostname": "monitor2",
            "port": 10002,
            "type": "etsi"
        }
    ],

    "parameters": {
        "country": "DE",
        "operator": "Cyber",
        "network_element": "10.8.2.4",
        "interception_point": "abcd1234",
        "username.123456": "user01@example.org",
        "username.123981": "user02@example.org",
        "username.981235": "user03@example.org",
        "snort.1.liid": "SNORT1",
        "snort.2.liid": "SNORT2"
    },

    "snort-alerters": [
        {
            "duration": 30,
            "path": "/tmp/alert"
        }
    ]
}

```

The `control` element is optional, if it exists, `cyberprobe` runs a management interface on the specified port. The `port`, `username` and `password` attributes must be specified. See Section 3.3 [Management interface], page 13, for how to communicate with that interface.

The `interfaces` block defines a set of interfaces to sniff. The `name` attribute is mandatory, the `filter` element is optional, and if specified should describe a BPF (Berkley Packet Filter) expression. The `delay` element can be used to specify, in seconds, the duration to wait before packets are processed. The delay is specified as a floating point decimal. If the interface name is of the form `vxlan:PORT` then a VXLAN receiver is run in the specified port number for reception of e.g. AWS Traffic Mirroring.

The `targets` block defines IP address to match. The `address` attribute defines the IP address with optional mask used for the address match. If a mask is specified, this describes the subset of the address which will be used for matching. For instance, if `192.168.0.0/16`

is specified, then a 16-bit mask will be applied, which makes this a class-B address match. That is, any address in the 192.168.0.0-192.168.255.255 range will match. If no mask is specified, then this is an exact match against a single address. The `device` attribute defines the device ID which will be applied if this particular IP address is detected.

The optional `network` attribute defines the network (ETSI NetworkElementID), which, if specified, will be transmitted in the ETSI stream, and delivered as the JSON `'network'` element in `cybermon` output. The address must be an IP address, and not a hostname. The address can be an IPv6 address if the `class` attribute is included, and set to `ipv6`.

Device IDs can occur in multiple places in the target block, allowing multiple IP addresses to match to the same device ID, but the same IP address/mask specifier should only occur once in the target block.

If subnetwork ranges overlap, the longest prefix match applies.

The `device` and `network` can contain template constructs:

<code>'%i'</code>	This is replaced with the IP address which causes a match.
<code>'%s'</code>	This is replaced with the IP address in the target rule - useful if this is a subnetwork address.
<code>'%m'</code>	This is replaced with the source MAC address in the header of the packet which causes a match.
<code>'%v'</code>	This is replaced with the VLAN ID in the header of the packet which causes a match.
<code>'%'</code>	This is replaced with a literal %.

The `endpoints` block defines a set of addresses for delivery. The `hostname` and `port` attributes should be used to describe the endpoint address. Type `type` attribute should be `nhis1.1` or `etsi` to specify which output stream format to use. The `transport` describe the transport type, which should be `tcp` for standard TCP stream, or `tls` for an SSL/TLS stream. If TLS is invoked, the attributes `certificate`, `key` and `trusted-ca` should be specified, with filenames for client certificate, private key, and a trust CA chain. These should all be in PEM format.

The optional `parameters` block defines a set of parameters which are only used in ETSI delivery. Each parameter element should have a `key` and a `value` attribute. The parameter values for `country`, `operator`, `network_element` and `interception_point` describe values which are used in the `PSHeader` and `IRI` constructs. The parameters with prefix `username.` describe values for the `username` values in the `IPIRI` construct in ETSI LI. The `key` value is the literal `username.` suffixed with the device ID. If such an entry is present, it is used for the `username`. All parameters are optional, meaningless defaults (e.g. `unknown`) will be used if not specified. The `etsi-streams` parameter specifies the number of TCP streams which will be opened for delivery, the default being 12. This feature potentially increases throughput, and is useful if the destination is a load-balanced resource.

9.3 cyberprobe-cli invocation

`cyberprobe-cli` connects to `cyberprobe` on the management port to allow dynamic administration. This permits dynamic management of resources.

Note: You can end up in a confusing situation if you use both the configuration file, and the management interface to configure resources. It is best to use one or the other. You can safely use the configuration file for resources that you don't intend to change through the management interface, but you shouldn't use both the configuration file and management interface to change the same resources.

Synopsis:

```
cyberprobe-cli HOST PORT
```

Example:

```
cyberprobe-cli vpn-host031 8888
```

'HOST' Specifies the hostname or IP address of the host to connect to.

'PORT' Specifies the management port number.

Upon connection, you are prompted to enter a username and password. Upon successful authentication, you are then offered a command line prompt for administration commands.

9.4 cyberprobe-cli commands

The following commands are supported by `cyberprobe-cli`:

```
'add endpoint HOST PORT TYPE [TRANSPORT [KEY CERT CA]]'
```

Adds a delivery endpoint.

'HOST' Specifies the delivery host.

'PORT' Specifies TCP port to deliver to.

'TYPE' Can be one of 'nhis' or 'etsi' for delivery protocol.

'TRANSPORT'

Can be one of 'tcp' or 'tls' for TCP or TLS transports. Defaults to 'tcp'.

'KEY' Filename of a key file in PEM format if 'tls' is specified.

'CERT' Filename of an X.509 file in PEM format if 'tls' is specified.

'TRANSPORT'

Filename of trusted CA certs in PEM format if 'tls' is specified.

Note: It is not possible to specify the appropriate transport parameters for TLS delivery using the management interface currently.

```
'add interface INTERFACE [DELAY [FILTER]]'
```

Adds an interface for packet sniffing.

'INTERFACE'

Interface name.

'DELAY' Delay between packet acquisition and delivery. Defaults to zero.

'FILTER' Optional, specifies a filter to be applied for positive selection of packets, in BPF / libpcap format.

- `'add parameter KEY VALUE'`
Adds a parameter.
- `'KEY'` Parameter key.
 - `'VALUE'` Parameter value.
- `'add target DEVICE PROTOCOL ADDRESS'`
Adds an address target for packet capture.
- `'DEVICE'` Device identifier.
 - `'PROTOCOL'`
Address protocol, one of `'ipv4'` or `'ipv6'`.
 - `'ADDRESS'` Address value, in IPv4 or IPv6 format, according to the PROTO-
COL value. Optionally can have a `'/mask'` suffix.
- `'quit'` Causes the client to close the connection and terminate.
- `'remove endpoint HOST PORT TYPE [TRANSPORT [KEY CERT CHAIN]]'`
Removes an endpoint added through the `'add endpoint'` command. The HOST, PORT TYPE and TRANSPORT, ... values are the same as for `'add endpoint'`.
- `'remove interface INTERFACE [DELAY [FILTER]]'`
Removes an interface added through the `'add interface'` command. The INTERFACE, DELAY and FILTER values are the same as for `'add interface'`.
- `'remove paramter KEY VALUE'`
Removes a paramter added through the `'add parameter'` command. The KEY and VALUE values are the same as for `'remove parameter'`.
- `'remove target DEVICE PROTOCOL ADDRESS'`
Removes a target added through the `'remove target'` command. The PROTOCOL and ADDRESS values are the same as for `'add target'`.
- `'show endpoints'`
Displays a table showing endpoints.
- `'show interfaces'`
Displays a table showing interfaces.
- `'show parameters'`
Displays a table showing parameters.
- `'show targets'`
Displays a table showing targets.

9.5 eventstream-service invocation

`eventstream-service` is a demonstrator gRPC service for cyberprobe gRPC. It isn't particularly useful for anything other than demo/debugging/diagnosing gRPC problems.

It receives gRPC requests containing event data, and outputs these in a JSON form, one event per line. This is a default mapping for Protobuf data determined by the Protobuf libraries, and is not identical to Cyberprobe JSON format.

The `eventstream-service.C` code may be useful in building your own gRPC service.

Synopsis:

```
eventstream-service [HOST:PORT]
```

Example:

```
eventstream-service 0.0.0.0:9100
```

‘HOST’ Specifies the hostname or IP address to bind this service to, to receive requests. 0.0.0.0 means any address.

‘PORT’ Specifies the port number to listen on.

9.6 Output streaming protocols

cyberprobe supports packet output in one of two output formats, which are both LI formats. LI formats were chosen as they set good, open standards for streaming packets to a destination. There are also existing security products such as firewalls, and analysis tools which understand with these protocols. The two formats are ETSI LI and NHIS 1.1.

ETSI LI

The first of the formats supported is the ETSI LI format (see ETSI TS 102 232), which is used in Europe and internationally. The protocol is described using an ASN.1 specification which can be downloaded from the ETSI web-site. Google can find the standards. The overarching TS 102 232-1 standard describes the transport, while the TS 102 232-3 standard describes putting the IP packets in the transport.

Those adverse to the use of ASN.1 technology may prefer the second format.

NHIS LI

NHIS 1.1 which was defined for use in the UK in the 90s, based on GLIC in ETSI TS 101 671. The protocol is a much simpler header protocol than ETSI LI, and needs less work to decode.

The standard was available on the internet on the <http://gliif.org> website, but that web-site has recently gone offline.

The bluffers guide to decoding goes...

- The first 32 bytes after TCP connection are a header. Ignore the first 4 bytes, the latter 28 bytes are the LIID / device ID, represented as an ASCII string. Unused bytes following the LIID / device ID are set to zero to pad out to 32 bytes.
- Once the start header is sent, the following data consists of IP packets pre-fixed by a 20 byte header. The only information of note in each 20 byte header is a 2-byte length field at offset 2 (network byte order). This tells you the length of the IP packet.
- The IP packets are transmitted until the TCP connection closes. A separate TCP connection is used for each LIID / device ID.

Output semantics

`cyberprobe` automatically reconnects to failed destinations, but the buffering strategy is very simple. When destinations fail, the packets are buffered in a small queue, but there is limited buffering, so once the queue fills, packets will start to be dropped. The locking strategy is simple, so loss of a single endpoint will currently result in data loss to all endpoints. This may be a problem for operational scenarios where high data availability is required.

`cyberprobe` includes some code to decode the ETSI and NHIS streams, and also includes two test utilities, `etsi-rcvr` and `nhis11-rcvr` which listen on a specified port number, decode the stream data, and forward in PCAP format on standard output. Example usage would be:

```
etsi-rcvr 10001 | tcpdump -n -r-
nhis11-rcvr 10000 | tcpdump -n -r-
```

9.7 Management protocol

Overview

The management interface is a simple interface which supports studying and dynamically changing the `cyberprobe` configuration: endpoints, targets and interfaces.

The configuration file specifies a port number, and username and password for the interface.

The interface is intended to be used programmatically. It is a request/response interface.

Note that the protocol is in clear, so should not be used across a hostile network.

Request structure

Each request is a JSON object encoded on a single line terminated with ‘NEWLINE’. Each request is required to have an `action` field which describes the action to take. One action is special: `auth`; other actions cannot be used until authentication has taken place.

Example request:

```
{"action":"auth","password":"admin","username":"horse-battery-staple"}
```

Response structure

Each response is preceded by a base-10 encoded human-readable byte length terminated by ‘NEWLINE’ after which the response is sent. Response is a JSON payload. The `status` field contains a numeric response code, statuses in the range 200-299 indicate success. The `message` field contains a human-readable response string, which will be an error message in the error case.

Other fields depend on the request.

Actions

Here is the list of supported actions. JSON has been pretty-printed to aid understanding.

The following values of the `action` field are supported:

auth Must be accompanied by valid `username` and `password` fields in order to authenticate. The response contains `status` and `message` fields.

Example request:

```
{
  "action": "auth",
  "password": "admin",
  "username": "horse-battery-staple"
}
```

Example response:

```
{"message": "Authenticated.", "status": 200}
```

add-interface

Starts packet capture from an interface. Request should have an `interface` field containing an interface specification.

Example request:

```
{
  "action": "add-interface",
  "interface": {
    "delay": 0.5,
    "filter": "not port 9876",
    "interface": "vxlan:9876"
  }
}
```

Example response:

```
{"message": "Interface added.", "status": 200}
```

remove-interface

Removes a previously enabled packet capture.

Example request:

```
{
  "action": "remove-interface",
  "interface": {
    "delay": 0.5,
    "filter": "not port 9876",
    "interface": "vxlan:9876"
  }
}
```

Example response:

```
{"message": "Interface removed.", "status": 200}
```

get-interfaces

Lists all interfaces, output is format `iface:delay:filter`.

Example request:

```
{
```

```
    "action": "get-interfaces"
  }
```

Example response:

```
{
  "interfaces": [
    {
      "delay": 0.5,
      "filter": "not port 10001 and not port 10002",
      "interface": "vxlan:4789"
    },
    {
      "delay": 0.3
      "filter": "",
      "interface": "vxlan:4790"
    },
    {
      "delay": 0.5,
      "filter": "not port 9876",
      "interface": "vxlan:9876"
    }
  ],
  "message": "Interfaces list.",
  "status": 201
}
```

add-endpoint

Adds an endpoint to delivery data to.

Example request:

```
{
  "action": "add-endpoint",
  "endpoint": {
    "certificate": "cert.crt",
    "hostname": "receiver",
    "key": "key.pem",
    "port": 10000,
    "transport": "tls",
    "trusted-ca": "ca.crt",
    "type": "etsi"
  }
}
```

Example response:

```
{"message": "Endpoint added.", "status": 200}
```

remove-endpoint

Removes a previously enabled endpoint.

Example request:

```
{
```

```

    "action": "remove-endpoint",
    "endpoint": {
      "certificate": "cert.crt",
      "hostname": "receiver",
      "key": "key.pem",
      "port": 10000,
      "transport": "tls",
      "trusted-ca": "ca.crt",
      "type": "etsi"
    }
  }
}

```

Example response:

```

{"message": "Endpoint removed.,"status":200}

```

get-endpoints

Gets the endpoint list.

Example request:

```

{"action": "get-endpoints"}

```

Example response:

```

{
  "endpoints": [
    {
      "hostname": "localhost",
      "port": 9000,
      "transport": "tcp",
      "type": "etsi"
    },
    {
      "hostname": "localhost",
      "port": 9002,
      "transport": "tcp",
      "type": "nhis1.1"
    },
    {
      "certificate": "cert.crt",
      "hostname": "receiver",
      "key": "key.pem",
      "port": 10000,
      "transport": "tls",
      "trusted-ca": "ca.crt",
      "type": "etsi"
    }
  ],
  "message": "Endpoints list.,"
  "status": 201
}

```

add-target

Adds a new targeted IP address.

Example requests:

```
{
  "action": "add-target",
  "target": {
    "address": "1.2.3.0/24",
    "class": "ipv4",
    "device": "my-machine4",
    "network": "my-network"
  }
}

{
  "action": "add-target",
  "target": {
    "address": "fe80:e015:e897::/24",
    "class": "ipv6",
    "device": "my-machine4",
    "network": ""
  }
}
```

Example response:

```
{"message":"Target added.,"status":200}
```

remove-target

Removes a previously targeted IP address.

Example requests:

```
{
  "action": "remove-target",
  "target": {
    "address": "1.2.3.0/24",
    "class": "ipv4",
    "device": "my-machine4",
    "network": "my-network"
  }
}

{
  "action": "remove-target",
  "target": {
    "address": "fe80:e015:e897::/24",
    "class": "ipv6",
    "device": "my-machine4",
    "network": ""
  }
}
```

Example response:

```
{"message": "Target removed.", "status": 200}
```

get-targets

Lists targets

Example request:

```
{"action": "get-targets"}
```

Example response:

```
{
  "message": "Target list.",
  "status": 201,
  "targets": [
    {
      "address": "10.0.0.0/8",
      "class": "ipv4",
      "device": "my-machine2",
      "network": ""
    },
    {
      "address": "1.2.3.0/24",
      "class": "ipv4",
      "device": "my-machine4",
      "network": "my-network"
    },
    {
      "address": "fe80:4124:5696::/48",
      "class": "ipv6",
      "device": "my-machine3",
      "network": ""
    }
  ]
}
```

add-parameter

Adds a new parameter, or changes a parameter value.

Example request:

```
{
  "action": "add-parameter",
  "parameter": {
    "key": "key",
    "value": "value"
  }
}
```

Example response:

```
{"message": "Parameter added.", "status": 200}
```

remove-parameter

Removes a parameter value.

Example request:

```
{
  "action": "remove-parameter",
  "parameter": {
    "key": "key",
    "value": "value"
  }
}
```

Example response:

```
{"message":"Parameter removed.,"status":200}
```

get-parameters

Lists parameters.

Example request:

```
{"action":"get-parameters"}
{
  "message": "Parameters list.",
  "parameters": [
    {
      "key": "asd",
      "value": "def"
    },
    {
      "key": "bunchy",
      "value": "loss"
    },
    {
      "key": "key",
      "value": "value"
    }
  ],
  "status": 201
}
```

Status codes

Error codes always start with 3 or 5. A 3xx error code results from something which is your fault e.g. procedural or syntactic violation, 5xx error codes result from errors internal to the system. This is still probably your fault :) e.g. specifying an interface which doesn't exist.

A 2xx means you didn't do anything wrong, and the command worked.

9.8 cybermon invocation

`cybermon` is a configurable network packet stream analyser. It is designed to receive packets from `cyberprobe`, analyse them and generate session/transport level events which result in user-configurable actions. For each event, a call is made to a Lua script which the caller provides. Synposes:

```
cybermon [--help] [--transport TRANSPORT] [--port PORT] [--key KEY]
        [--certificate CERT] [--trusted-ca CHAIN] [--pcap PCAP-FILE]
        [--config CONFIG] [--vxlan VXLAN-PORT] [--interface IFACE]
        [--device DEVICE] [--time-limit LIMIT]
```

- *TRANSPORT* is either ‘tcp’ or ‘tls’. If ‘tls’ is specified, ‘cybermon’ expects to read data over TLS. In TLS mode, it is necessary to specify the key, certificate, and trusted CA files.
- *PORT* is a TCP port number. This form of the command runs as a TCP server listening for ETSI LI streams. See [ETSI LI], page 40.
- *KEY* specifies a filename for the private key in PEM format. Only used in TLS mode.
- *CERT* specifies a filename for the public certificate in PEM format. Only used in TLS mode.
- *CHAIN* specifies a filename for trusted CA keys in PEM format. Only used in TLS mode.
- *PCAP-FILE* is a PCAP file to read. This form of the command reads the PCAP file, and then exits. If the file is ‘-’, standard input is read.
- *CONFIG* is a Lua configuration file, which specifies the action `cybermon` should take when certain events are observed. See Section 9.9 [cybermon configuration], page 48.
- *VXLAN-PORT* is a UDP port number. This describes a port number to listen on for VXLAN protocol. This scenario is used to receive traffic-mirrored data on AWS.
- *IFACE* is a network interface to sniff for packets as input.
- *DEVICE* is a device-name to include in the output events. Use this to specify the device for PCAP files, interfaces or VXLAN input if you don’t want the default placeholder.
- *LIMIT* is the length of time to run for (in seconds). The program exits after this period.

9.9 cybermon configuration

Overview

Cybermon is a simple monitoring tool. It receives the ETSI protocol, decodes the protocols, and makes decoded information available for further handling which you can specify. The tool is very much a work in progress - it has limited protocol decode capability at the moment, but there’s enough there to demonstrate the idea. Usage

Usage is: `cybermon -p <port-number> -c <config-file>`

You specify a port number to receive data on, and a configuration file written in Lua. Lua is a simple but powerful scripting language. Here’s an example to help you see how the configuration is used.

Example configuration

The configuration file is there to provide functions which get called when certain events occur. The calling interface is fairly simple at the moment, and over time, expect to see a richer interface develop.

To start with, we create the structure of the configuration file. Call it something with a `.lua` extension e.g. `config.lua` so that your editor knows how to indent the code. The basic structure is a module with a number of functions:

```
local observer = {}

-- Called when an event occurs
observer.event = function(e)
    print(e.action)
end

-- Return the table
return observer
```

LUA event calls

The configuration file is expected to provide the event function which is called with a single argument, an event, in response to `cybermon` events. The event looks like a table, but is a userdata object. While the object has fields which can be read, they cannot be changed in the event object itself.

There are standard fields in the event object:

```
device
    Return the device identifier.

time
    The time of the event.

action
    The action which caused the event.

json()
    Function, returns the event in JSON form. See Section 9.11 [Cybermon JSON
    message format], page 66.

protobuf()
    Method, returns the event in protobuf wire format. This is only implemented
    if protobuf support is detected during build). See Section 9.12 [Cybermon
    protobuf event format], page 77.
```

The structure of the event object depends on the `action` field.

```
trigger_up
    Called when an attacker is seen coming on-stream. The event contains the
    following fields:

time
    time of event in format YYYYMMDDTHHMMSS.sssZ
```

`device` describes the device ID
`address` contains the triggering IP address in string form.

trigger_down

Called when an attacker is seen going off-stream. The event contains the following fields:

`time` time of event in format `YYYYMMDDTHHMMSS.sssZ`
`device` describes the device ID

connection_up

Called when a stream-based connection (e.g. TCP) is made. The event contains the following fields:

`time` time of event in format `YYYYMMDDTHHMMSS.sssZ`
`context` a LUA userdata variable which can't be access directly, but can be used with the functions described below to access further information from `cybermon`.

connection_down

Similar to `connection_up`, called when a connection closes. The event contains the following fields:

`time` time of event in format `YYYYMMDDTHHMMSS.sssZ`
`context` a LUA userdata variable which can't be access directly, but can be used with the functions described below to access further information from `cybermon`.

icmp

Called when an ICMP message is detected. The event contains the following fields:

`time` time of event in format `YYYYMMDDTHHMMSS.sssZ`
`context` a LUA userdata variable which can't be access directly, but can be used with the functions described below to access further information from `cybermon`.
`type` ICMP type value
`code` ICMP code value

http_request

Called when an HTTP request is observed. The event contains the following fields:

`time` time of event in format `YYYYMMDDTHHMMSS.sssZ`
`context` a LUA userdata variable which can't be access directly, but can be used with the functions described below to access further information from `cybermon`.
`method` HTTP method
`url` HTTP URL (derived from host and path).

header HTTP header values in a Lua associative array.
body HTTP request body, if one exists.

http_response

Called when an HTTP response is observed. The event contains the following fields:

time time of event in format `YYYYMMDDTHHMMSS.sssZ`
context a LUA userdata variable which can't be access directly, but can be used with the functions described below to access further information from `cybermon`.
code HTTP response code
status HTTP response status
header HTTP response header, a Lua associative array.
body HTTP response body.

smtp_command

Called when an SMTP command is observed i.e. a single line message going to the server from a client. The event contains the following fields:

time time of event in format `YYYYMMDDTHHMMSS.sssZ`
context a LUA userdata variable which can't be access directly, but can be used with the functions described below to access further information from `cybermon`.
command the SMTP command

smtp_response

Called when an SMTP response is observed. The event contains the following fields:

time time of event in format `YYYYMMDDTHHMMSS.sssZ`
context a LUA userdata variable which can't be access directly, but can be used with the functions described below to access further information from `cybermon`.
status the SMTP status value e.g. 200
text SMTP human-readable response text, an array of strings

smtp_data

Called when an SMTP payload is observed i.e. the body of text following the DATA command. To aid processing, the SMTP protocol processor assembles information from other commands. The event contains the following fields:

time time of event in format `YYYYMMDDTHHMMSS.sssZ`
context a LUA userdata variable which can't be access directly, but can be used with the functions described below to access further information

<code>from</code>	contains the email From address described in the MAIL FROM command.
<code>to</code>	a list of addresses contained in all RCPT TO commands. An array of strings.
<code>data</code>	contains the email body - it will be an RFC822 payload.

ftp_command

Called when an FTP command is observed i.e. a single line message going to the server from a client. The event contains the following fields:

<code>time</code>	time of event in format YYYYMMDDTHHMMSS.sssZ
<code>context</code>	a LUA userdata variable which can't be access directly, but can be used with the functions described below to access further information from <code>cybermon</code> .
<code>command</code>	contains the command string.

ftp_response

Called when an FTP response is observed. That is, status going from server to client following a command. The event contains the following fields:

<code>time</code>	time of event in format YYYYMMDDTHHMMSS.sssZ
<code>context</code>	a LUA userdata variable which can't be access directly, but can be used with the functions described below to access further information from <code>cybermon</code> .
<code>status</code>	FTP status code e.g. 200.
<code>text</code>	contains the response text, described as a list of strings. Responses may occur over a number of lines, hence the parameter is a list: For single-line responses, there is only a single item in the list.

dns_message

Called when a DNS message is observed. The event contains the following fields:

<code>time</code>	time of event in format YYYYMMDDTHHMMSS.sssZ
<code>context</code>	a LUA userdata variable which can't be access directly, but can be used with the functions described below to access further information from <code>cybermon</code> .
<code>header</code>	describes the DNS header
<code>query</code>	the DNS queries
<code>answer</code>	contains the answers in a response message
<code>auth</code>	DNS nameserver authority descriptions
<code>add</code>	provides additional DNS records

ntp_timestamp_message

Called when a NTP timestamp message is observed. The event contains the following fields:

<code>time</code>	time of event in format YYYYMMDDTHHMMSS.sssZ
-------------------	--

context a LUA userdata variable which can't be access directly, but can be used with the functions described below to access further information from `cybermon`.

header the NTP header

timestamp
contains the specific timestamp information

`ntp_control_message`

Called when a NTP control message is observed. The event contains the following fields:

time time of event in format `YYYYMMDDTHHMMSS.sssZ`

context a LUA userdata variable which can't be access directly, but can be used with the functions described below to access further information from `cybermon`.

header the NTP header

control specific NTP control information.

`ntp_private_message`

Called when a NTP control message is observed. The event contains the following fields:

time time of event in format `YYYYMMDDTHHMMSS.sssZ`

context a LUA userdata variable which can't be access directly, but can be used with the functions described below to access further information from `cybermon`.

header the NTP header

private specific NTP private information.

`unrecognised_datagram`

Called when a datagram is received using a protocol which isn't recognised. The event contains the following fields:

time time of event in format `YYYYMMDDTHHMMSS.sssZ`

context a LUA userdata variable which can't be access directly, but can be used with the functions described below to access further information from `cybermon`.

data the payload.

`unrecognised_stream`

Called when connection-orientated data is received using a protocol which isn't recognised. The event contains the following fields:

time time of event in format `YYYYMMDDTHHMMSS.sssZ`

context a LUA userdata variable which can't be access directly, but can be used with the functions described below to access further information from `cybermon`.

	data	the payload.
	position	the stream position of the payload in bytes. Starts at 0 when stream is connected, and increases with payload size.
imap		Called when an IMAP message is detected - this is currently a port number detection. The event contains the following fields:
	time	time of event in format <code>YYYYMMDDTHHMMSS.sssZ</code>
	context	a LUA userdata variable which can't be access directly, but can be used with the functions described below to access further information from <code>cybermon</code> .
	data	the payload.
imap_ssl		Called when an IMAP SSL message is detected. This is currently a port number detection. The event contains the following fields:
	time	time of event in format <code>YYYYMMDDTHHMMSS.sssZ</code>
	context	a LUA userdata variable which can't be access directly, but can be used with the functions described below to access further information from <code>cybermon</code> .
	data	the payload.
pop3		Called when a POP3 message is detected. This is currently a port number detection. The event contains the following fields:
	time	time of event in format <code>YYYYMMDDTHHMMSS.sssZ</code>
	context	a LUA userdata variable which can't be access directly, but can be used with the functions described below to access further information from <code>cybermon</code> .
	data	the payload.
pop3_ssl		Called when a POP3 SSL message is detected. This is currently a port number detection. The event contains the following fields:
	time	time of event in format <code>YYYYMMDDTHHMMSS.sssZ</code>
	context	a LUA userdata variable which can't be access directly, but can be used with the functions described below to access further information from <code>cybermon</code> .
	data	the payload.
sip_request		Called when a SIP request is observed. The event contains the following fields:
	time	time of event in format <code>YYYYMMDDTHHMMSS.sssZ</code>
	context	a LUA userdata variable which can't be access directly, but can be used with the functions described below to access further information from <code>cybermon</code> .
	from	SIP originator

	<code>to</code>	SIP destination
	<code>method</code>	SIP method
	<code>data</code>	the payload.
<code>sip_response</code>		Called when a SIP request is observed. The event contains the following fields:
	<code>time</code>	time of event in format <code>YYYYMMDDTHHMMSS.sssZ</code>
	<code>context</code>	a LUA userdata variable which can't be access directly, but can be used with the functions described below to access further information from <code>cybermon</code> .
	<code>code</code>	SIP response code
	<code>status</code>	SIP response status
	<code>from</code>	SIP originator
	<code>to</code>	SIP destination
	<code>data</code>	the payload.
<code>sip_ssl</code>		Called when a SIP SSL message is detected. This is currently a port number detection. The event contains the following fields:
	<code>time</code>	time of event in format <code>YYYYMMDDTHHMMSS.sssZ</code>
	<code>context</code>	a LUA userdata variable which can't be access directly, but can be used with the functions described below to access further information from <code>cybermon</code> .
	<code>data</code>	the payload.
<code>gre</code>		Called when a GRE message with an unknown ethertype is detected. The event contains the following fields:
	<code>time</code>	time of event in format <code>YYYYMMDDTHHMMSS.sssZ</code>
	<code>context</code>	a LUA userdata variable which can't be access directly, but can be used with the functions described below to access further information from <code>cybermon</code> .
	<code>next_proto</code>	the ethertype of the next protocol
	<code>key</code>	the key, if present. If the key is not present then it will default to 0.
	<code>sequence_number</code>	the sequence number, if present. If the sequence number is not present then it will default to 0.
	<code>payload</code>	the payload
<code>gre_pptp</code>		Called when a GRE PPTP message with an unknown ethertype is detected. The event contains the following fields:
	<code>time</code>	time of event in format <code>YYYYMMDDTHHMMSS.sssZ</code>

context a LUA userdata variable which can't be access directly, but can be used with the functions described below to access further information from `cybermon`.

next_proto the ethertype of the next protocol

call_id the call id

sequence_number the sequence number, if present. If the sequence number is not present then it will default to 0.

acknowledgement_number the acknowledgement number, if present. If the acknowledgement number is not present then it will default to 0.

payload_length the payload length

payload the payload

esp Called when an ESP packet is detected. The event contains the following fields:

time time of event in format `YYYYMMDDTHHMMSS.sssZ`

context a LUA userdata variable which can't be access directly, but can be used with the functions described below to access further information from `cybermon`.

spi the SPI

sequence_number the sequence number

payload_length the payload length

payload the payload

unrecognised_ip_protocol Called when an IP packet with an unhandled next protocol is detected. The event contains the following fields:

time time of event in format `YYYYMMDDTHHMMSS.sssZ`

context a LUA userdata variable which can't be access directly, but can be used with the functions described below to access further information from `cybermon`.

next_proto the protocol number of the next protocol

payload_length the payload length

payload the payload

wlan	Called when an 802.11 packet is detected. The event contains the following fields:
time	time of event in format <code>YYYYMMDDTHHMMSS.sssZ</code>
context	a LUA userdata variable which can't be access directly, but can be used with the functions described below to access further information from <code>cybermon</code> .
version	the 802.11 version
type	the type of the 802.11 dataframe
subtype	the subtype of the 802.11 dataframe
flags	the flags of the 802.11 dataframe
protected	the protected flag of the 802.11 dataframe, indicates if the payload is encrypted
duration	the duration
filt_addr	the filter MAC address
frag_num	the fragmentation number of the dataframe
seq_num	the sequence number of the dataframe
tls_unknown	Called when an unknown TLS message (i.e. one that isn't covered by further handling) is detected. The event contains the following fields:
time	time of event in format <code>YYYYMMDDTHHMMSS.sssZ</code>
context	a LUA userdata variable which can't be access directly, but can be used with the functions described below to access further information from <code>cybermon</code> .
tls	
version	The version of the TLS header.
content_type	The content type of the TLS message.
length	The length of the TLS message.
tls_client_hello	Called when a TLS Client Hello message is detected. The event contains the following fields:
time	time of event in format <code>YYYYMMDDTHHMMSS.sssZ</code>
context	a LUA userdata variable which can't be access directly, but can be used with the functions described below to access further information from <code>cybermon</code> .

tls

version	The TLS version specified in the client hello message.
session_id	The session ID of the message.
random_timestamp	The timestamp field in the random field of the TLS message.
random_data	The data field in the random field of the TLS message.
cipher_suites	An ordered array of the cipher suites from the message. Each entry is a table with id and name fields.
compression_methods	An ordered array of the compression methods from the message. Each entry is a table with id and name fields.
extensions	An ordered array of the extensions from the message. Each entry is a table with name , length and data fields. (data will only be present if the length > 0)

tls_server_hello

Called when a TLS Server Hello message is detected. The event contains the following fields:

time	time of event in format YYYYMMDDTHHMMSS.sssZ
context	a LUA userdata variable which can't be access directly, but can be used with the functions described below to access further information from cybermon .

tls

version	The TLS version specified in the server hello message.
session_id	The session ID of the message.
random_timestamp	The timestamp field in the random field of the TLS message.
random_data	The data field in the random field of the TLS message.
cipher_suite	The cipher suite from the message, as a table with id and name fields.
compression_method	The compression method from the message, as a table with id and name fields.

extensions

An ordered array of the extensions from the message. Each entry is a table with **name**, **length** and **data** fields. (**data** will only be present if the **length** > 0)

tls_server_key_exchange

Called when a TLS Server Key Exchange message is detected. The event contains the following fields:

time time of event in format YYYYMMDDTHHMMSS.sssZ

context a LUA userdata variable which can't be access directly, but can be used with the functions described below to access further information from cybermon.

tls**key_exchange_algorithm**

The key exchange algorithm being used.

curve_metadata

Metadata about the curve (if ecdh) being used, as key:value pairs.

public_key

The public key field as bytes.

signature_hash_algorithm

The signature hash algorithm field.

signature_algorithm

The signature algorithm field.

signature_hash

The signature hash field. As a hex string

tls_certificates

Called when a TLS certificates message is detected. The event contains the following fields:

time time of event in format YYYYMMDDTHHMMSS.sssZ

context a LUA userdata variable which can't be access directly, but can be used with the functions described below to access further information from cybermon.

tls**certificates**

an ordered array of certificates, each in bytes.

tls_server_hello_done

Called when a TLS Server Hello Done message is detected. The event contains the following fields:

time time of event in format YYYYMMDDTHHMMSS.sssZ

context a LUA userdata variable which can't be access directly, but can be used with the functions described below to access further information from `cybermon`.

`tls`

`tls_handshake_unknown`

Called when a TLS handshake message is detected, that isnt explicitly handled. The event contains the following fields:

time time of event in format `YYYYMMDDTHHMMSS.sssZ`

context a LUA userdata variable which can't be access directly, but can be used with the functions described below to access further information from `cybermon`.

`tls`

type the type of the handshake message

length the length of the handshake message

`tls_certificate_request`

Called when a TLS certificate request message is detected. The event contains the following fields:

time time of event in format `YYYYMMDDTHHMMSS.sssZ`

context a LUA userdata variable which can't be access directly, but can be used with the functions described below to access further information from `cybermon`.

`tls`

cert_types

An ordered array of certificate types

signature_algorithms

An ordered array of the Signature Algorithms from the message. Each entry is a table with `hash_algorithm` and `signature_algorithm` fields.

distinguished_names

the distinguished names field in bytes

`tls_client_key_exchange`

Called when a TLS client key exchange message is detected. The event contains the following fields:

time time of event in format `YYYYMMDDTHHMMSS.sssZ`

context a LUA userdata variable which can't be access directly, but can be used with the functions described below to access further information from `cybermon`.

`tls`

key the key in bytes

tls_certificate_verify

Called when a TLS certificate verify message is detected. The event contains the following fields:

time time of event in format `YYYYMMDDTHHMMSS.sssZ`

context a LUA userdata variable which can't be access directly, but can be used with the functions described below to access further information from `cybermon`.

tls

signature_algorithm
the Signature Algorithms from the message. As a table with `hash_algorithm` and `signature_algorithm` fields.

signature
the signature as a hex string

tls_change_cipher_spec

Called when a TLS change cipher spec message is detected. The event contains the following fields:

time time of event in format `YYYYMMDDTHHMMSS.sssZ`

context a LUA userdata variable which can't be access directly, but can be used with the functions described below to access further information from `cybermon`.

tls

val the value field

tls_handshake_finished

Called when a TLS handshake finished message is detected. The event contains the following fields:

time time of event in format `YYYYMMDDTHHMMSS.sssZ`

context a LUA userdata variable which can't be access directly, but can be used with the functions described below to access further information from `cybermon`.

tls

msg the encrypted message

tls_handshake_complete

Called when a TLS handshake has been completely finished - i.e. both sides of the communication have sent `change_cipher_spec` and `handshake_finished`. The event contains the following fields:

time time of event in format `YYYYMMDDTHHMMSS.sssZ`

context a LUA userdata variable which can't be access directly, but can be used with the functions described below to access further information from `cybermon`.

`tls`

`tls_application_data`

Called when a TLS application data message is detected. The event contains the following fields:

`time` time of event in format `YYYYMMDDTHHMMSS.sssZ`

`context` a LUA userdata variable which can't be access directly, but can be used with the functions described below to access further information from `cybermon`.

`tls`

`version` the version on the TLS header.

`data` the encrypted message.

Context object

From the LUA code there, the `context` variable has a number of method functions which can be called:

`context:get_type()`

Returns the protocol type of the context e.g. `http`, `tcp`, `udp`, `dns`, `ip4`

`context:get_parent()`

Returns the parent context relating to a context. This can be used to travel "up" the protocol stack. For example, call `get_parent` on a TCP context will return the IP context.

`context:get_src_addr()`

Returns the source address relating to a context. Returns two string variables: the first is the address class e.g. `ipv4`, the second is the address value e.g. `1.2.3.4`.

`context:get_dest_addr()`

Returns the destination address relating to a context. Returns two string variables: the first is the address class e.g. `ipv4`, the second is the address value e.g. `1.2.3.4`.

`context:get_reverse()`

Returns the context relating to the "other side" of a communication, but only if this has been identified. On an HTTP response, `get_reverse` will return the HTTP request. In the `http_request` function you will not be able to use `get_reverse` to find the HTTP response because the response does not exist at the point the request is identified.

`context:get_id()`

Returns a context's unique ID. Can be useful for tracking, or can be used as index into your own LUA structures to associate information with contexts.

`context:describe_src()`

Returns a human readable description of the protocol stack using source addresses.

`context:describe_dest()`
Returns a human readable description of the protocol stack using source addresses.

`context:get_device()`
Returns the trigger ID associated with a "target".

`context:get_network_info()`
Returns three variables: the network name (from ETSI NetworkElementID), the source and destination network addresses (IP addresses) for this data. These are in normal IP address string format. Network name is the empty string, if not provided in the input stream. See Section 9.2 [cyberprobe configuration], page 35, for specifying the network.

`context:get_trigger_info()`
Returns the IP address which triggered this collection, if known. If not, 0.0.0.0x is returned. This is in normal IP address string format.

`context:get_direction()`
Returns the direction of the event with respect to the target device, if known. This will be a string containing 'FROM_DEVICE', 'TO_DEVICE', or 'NOT_KNOWN'. The packet direction can only be determined if the ETSI stream delivery format is in use. cyberprobe works out packet direction with respect to the addresses specified in the cyberprobe.cfg file.

`context:forge_tcp_reset()`
Creates a TCP reset packet and directs it at the source address associated with this context. Must have TCP protocol present in the stack.

`context:forge_dns_response(header, queries, answers, add)`
Creates a DNS message and directs it at the source address associated with this context. The provided parameters are used as protocol data in the DNS encoder.

gRPC object

If gRPC support is compiled into cybermon, a gRPC call containing the event, conforming to eventstream protobuf format can be made by calling `grpc:observe(e, service)`. The first parameter is an event object, the second is a service address in 'host:port' format. The gRPC call is used to deliver an event asynchronously, and nothing is returned from the service. The `grpc:observe` call silently succeeds, and events are held in a queue until delivered. The call will block if the queue achieves a pre-defined defined limit.

```
observer = {}

observer.event = function(e)
  grpc:observe(e, "localhost:50051")
end

return observer
```

If protobuf support is compiled into cybermon, a protobuf representation of a cybermon event can be obtained by calling `e:protobuf()`. This obtains the event described in protobuf v3 wire format. No network communication takes place.

```
observer.event = function(e)
  x = e:protobuf()
  -- do something useful
end
```

See Section 9.12 [Cybermon protobuf event format], page 77, for details of the protobuf events.

9.10 cybermon example configurations

Example configuration files

`forge-dns.lua`

Example Lua script, spots DNS queries for ‘`example.org`’, and responds with made-up IP addresses.

`forge-reset.lua`

Example script, spots TCP port 22 sessions (which is the port number normally used for SSH sessions). If detected, a TCP reset is forged.

`hexdump.lua`

Like `monitor.lua`, but adds a hex-dump of event payloads to the output.

`monitor.lua`

For each Lua event, outputs a plain text summary of the output on standard output.

`zeromq.lua`

For each Lua event, a JSON record is formatted and published to a ZeroMQ queue on port 5555. See Section 9.11 [Cybermon JSON message format], page 66.

`amqp-topic.lua`

For each Lua event, a JSON record is formatted and published to a RabbitMQ broker. See Section 9.11 [Cybermon JSON message format], page 66. Environment variables ‘`AMQP_BROKER`’, ‘`AMQP_EXCHANGE`’, ‘`AMQP_ROUTING_KEY`’ can be used to tailor delivery.

`pulsar.lua`

For each Lua event, an event is formatted in protobuf wire format and published to a Pulsar exchange. See Section 9.12 [Cybermon protobuf event format], page 77, for details. The following environment variables configure the exchange:

‘`PULSAR_BROKER`’

Specifies broker location. Currently we use the Pulsar websocket endpoint, default is ‘`ws://localhost:8080`’.

- `'PULSAR_TENANT'`
Specifies tenant, default is `'public'`.
- `'PULSAR_PERSISTENCY'`
Specifies persistency of messages, default is `'persistent'`.
- `'PULSAR_NAMESPACE'`
Specifies namespace, default is `'default'`.
- `'PULSAR_TOPIC'`
Specifies topic, default is `'cyberprobe'`.

redis.lua

For each Lua event, a JSON record is formatted and RPUSH'd to a Redis server defined by the `REDIS_SERVER` environment variable which should be in `HOST:PORT` form. Each message is JSON format, see Section 9.11 [Cybermon JSON message format], page 66.

json.lua

For each Lua event, a JSON record is formatted and delivered to standard output. Each message is JSON format, see Section 9.11 [Cybermon JSON message format], page 66.

quiet.lua

Does nothing. This is an empty code shell, and a good template to write your own event handler.

protobuf.lua

Outputs protobuf-formatted messages in base64 format, one message per line. Probably only useful for testing.

grpc.lua

For each Lua event, a gRPC call is made to a service defined by the `GRPC_SERVICE` environment variable which should be in `HOST:PORT` form. Each message is protobuf format as defined by the `cyberprobe.proto` definition.

Utilities

The `/usr/local/etc/cyberprobe/util` directory contains some Lua utilities which can be used by other Lua configuration files. They can be loaded as modules e.g.

```
local addr = require("util.addresses")
```

The utilities are:

addresses.lua

Some `cybermon` address handling functions.

json.lua The real JSON formatting is done here.

9.11 Cybermon JSON message format

Cybermon's `'amqp-topic.lua'`, `'zeromq.lua'` and `'redis.lua'` configuration files transmit messages in JSON format. Each message is a JSON object with the following fields:

<code>'id'</code>	Unique ID for the event: UUID format (e.g. <code>3c55d830-8d99-48a1-c8cd-ca77514a6d10</code>).
<code>'device'</code>	Device identifier / LIID.
<code>'network'</code>	Network identifier, if ETSI stream delivery is used, and the <code>network</code> identifier is used in <code>cyberprobe.cfg</code> . See Section 9.2 [<code>cyberprobe</code> configuration], page 35,
<code>'origin'</code>	If known, set to <code>'network'</code> or <code>'device'</code> depending on whether or not the event is observed to originate from the device or, the device is the recipient. This assertion is made by comparing the targeted IP address with the source/destination IP addresses of an event. The <code>'origin'</code> field will only be useful if a device IP address is set in the <code>cyberprobe.cfg</code> file; if a wildcard address e.g. <code>'0.0.0.0/0'</code> is set, it is not defined which of the source or destination addresses will trigger in <code>cyberprobe</code> , and so the <code>'origin'</code> field will be of no value. Further, the field is only known if the ETSI stream format is used to deliver from <code>cyberprobe</code> to <code>cybermon</code> .
<code>'action'</code>	The event type. One of: <ul style="list-style-type: none"> <code>'connected_up'</code> Records the creation of a stream-orientated connection (currently, only TCP). This event is created for all connections whether the protocol is recognised or not. <code>'connected_down'</code> Records the closing of a stream-orientated connection (currently, only TCP). This event is created for all connections whether the protocol is recognised or not. <code>'unrecognised_stream'</code> Records the sending of a PDU on a data stream transport (currently, only TCP) whose protocol has not been recognised. <code>'unrecognised_datagram'</code> Records the sending of a PDU on a connection-less transport (currently, only UDP) whose protocol has not been recognised. <code>'http_request'</code> Records the sending of an HTTP request. <code>'http_response'</code> Records the sending of an HTTP response. <code>'dns_message'</code> Records the sending of a DNS message (request and response). <code>'icmp'</code> Records the sending of an ICMP message.

- `'smtp_command'`
Records the sending of an SMTP command. This is a message from client to server. Data commands are not recorded with this event - there is an `'smtp_data'` event which records this.
- `'smtp_response'`
Records the sending of a response to an SMTP command. This is a status message from server to client.
- `'smtp_data'`
Records an SMTP data transaction, including the full SMTP data payload (essentially an email).
- `'ftp_command'`
Records an FTP command (client to server).
- `'ftp_response'`
Records an FTP response (server to client).
- `'ntp_message'`
Records the sending of a NTP message, including the NTP hdr (mode, version, leap second indicator)
- `'imap'` Records the presence of IMAP data.
- `'imap_ssl'`
Records the presence of IMAP SSL data.
- `'pop3'` Records the presence of POP.3 data.
- `'pop3_ssl'`
Records the presence of POP3 SSL data.
- `'sip_request'`
Records the sending of a SIP request.
- `'sip_response'`
Records the sending of a SIP response.
- `'sip_ssl'` Records the presence of SIP SSL data.
- `'gre'` Records the presence of a GRE data frame with an unhandled ether-type.
- `'grep_pptp'`
Records the presence of a GRE PPTP data frame with an unhandled ethertype.
- `'esp'` Records the presence of ESP data.
- `'unrecognised_ip_protocol'`
Records the sending of a PDU over IP with an unrecognised next protocol.
- `'wlan'` Records the presence of 802.11 data.
- `'tls_unknown'`
Records the presence of a tls message.

<code>'tls_client_hello'</code>	Records the presence of a tls client hello message.
<code>'tls_server_hello'</code>	Records the presence of a tls server hello message.
<code>'tls_certificates'</code>	Records the presence of a tls certificates message.
<code>'tls_server_key_exchange'</code>	Records the presence of a tls server key exchange message.
<code>'tls_server_hello_done'</code>	Records the presence of a tls server hello done message.
<code>'tls_handshake_unknown'</code>	Records the presence of a tls handshake message.
<code>'tls_certificate_request'</code>	Records the presence of a tls certificate request message.
<code>'tls_client_key_exchange'</code>	Records the presence of a tls client_key exchange message.
<code>'tls_certificate_verify'</code>	Records the presence of a tls certificate verify message.
<code>'tls_change_cipher_spec'</code>	Records the presence of a tls change cipher spec message.
<code>'tls_handshake_finished'</code>	Records the presence of a tls handshake finished message.
<code>'tls_handshake_complete'</code>	Records the that both sides of the TLS handshake are complete.
<code>'tls_application_data'</code>	Records the presence of a tls application data message.
<code>'url'</code>	The URL identified in any protocol which supports URL request/response e.g. HTTP.
<code>'src'</code>	A list of source protocol addresses travelling up the stack. Strings are of the form <code>protocol:address</code> or <code>protocol</code> . Example protocol types are: <code>tcp</code> , <code>udp</code> and <code>ipv4</code> .
<code>'dest'</code>	A list of source protocol addresses travelling up the stack. Strings are of the form <code>protocol:address</code> or <code>protocol</code> . Example protocol types are: <code>tcp</code> , <code>udp</code> and <code>ipv4</code> .
<code>'time'</code>	Time of the event in the form <code>2017-04-24T12:34:24.341Z</code> .
<code>'dns_message'</code>	Emitted when action is <code>dns_message</code> . <code>dns_message</code> is itself a JSON object containing the following fields: <ul style="list-style-type: none"><code>'query'</code> Describes DNS query records in <code>'dns_message'</code> actions. Is a list of objects with <code>'name'</code>, <code>'type'</code> and <code>'class'</code> fields containing strings for name, type and class.

`'answer'` Describes DNS answer records in `'dns_message'` actions. Is a list of objects with `'name'`, `'type'` and `'class'` and `'address'` fields containing strings for name, type and class and IP address.

`'type'` DNS message type, one of `'query'` or `'response'`.

`'unrecognised_datagram'`

Emitted when `action` is `unrecognised_datagram`. The value is a JSON object containing the following fields:

`'datagram'`

The datagram body, Base64 encoded.

`'unrecognised_stream'`

Emitted when `action` is `unrecognised_stream`. The value is a JSON object containing the following fields:

`'payload'` The datagram body, Base64 encoded.

`'position'`

The stream position, 0 for a newly connected stream, increases with each payload size.

`'icmp'` Emitted when `action` is `icmp`. The value is a JSON object containing the following fields:

`'type'` ICMP type field.

`'code'` ICMP code field.

`'data'` Raw ICMP payload, Base64 encoded.

`'http_request'`

Emitted when `action` is `http_request`. The value is a JSON object containing the following fields:

`'method'` HTTP method.

`'header'` An object containing key/value pairs for HTTP header.

`'body'` HTTP body, Base64 encoded.

`'http_response'`

Emitted when `action` is `http_response`. The value is a JSON object containing the following fields:

`'code'` HTTP code field e.g. 200.

`'status'` HTTP status field e.g. OK.

`'header'` An object containing key/value pairs for HTTP header.

`'body'` HTTP body, Base64 encoded.

`'sip_request'`

Emitted when `action` is `sip_request`. The value is a JSON object containing the following fields:

`'method'` SIP method e.g. INVITE.

- `'from'` The SIP caller address.
 - `'to'` The SIP callee address.
 - `'data'` SIP message body, base64-encoded.
- `'sip_response'`
Emitted when `action` is `sip_response`. The value is a JSON object containing the following fields:
 - `'code'` SIP response code.
 - `'status'` SIP response status.
 - `'from'` The SIP caller address.
 - `'to'` The SIP callee address.
 - `'data'` SIP message body, base64-encoded.
- `'sip_ssl'` Emitted when `action` is `sip_ssl`. The value is a JSON object containing the following fields:
 - `'payload'` The message payload, base64-encoded.
- `'imap'` Emitted when `action` is `imap`. The value is a JSON object containing the following fields:
 - `'payload'` The message payload, base64-encoded.
- `'imap_ssl'`
Emitted when `action` is `imap_ssl`. The value is a JSON object containing the following fields:
 - `'payload'` The message payload, base64-encoded.
- `'pop3'` Emitted when `action` is `pop3`. The value is a JSON object containing the following fields:
 - `'payload'` The message payload, base64-encoded.
- `'pop3_ssl'`
Emitted when `action` is `pop3_ssl`. The value is a JSON object containing the following fields:
 - `'payload'` The message payload, base64-encoded.
- `'ntp_timestamp'`
Emitted when `action` is `ntp_timestamp`. The value is a JSON object containing the following fields:
 - `'version'` NTP header version field.
 - `'mode'` NTP header mode field.
- `'ntp_control'`
Emitted when `action` is `ntp_control`. The value is a JSON object containing the following fields:
 - `'version'` NTP header version field.

- 'mode' NTP header mode field.
- 'ntp_private'
 - Emitted when `action` is `ntp_private`. The value is a JSON object containing the following fields:
 - 'version' NTP header version field.
 - 'mode' NTP header mode field.
- 'ftp_command'
 - Emitted when `action` is `ftp_command`. The value is a JSON object containing the following fields:
 - 'command' The FTP command e.g. PASV.
- 'ftp_response'
 - Emitted when `action` is `ftp_response`. The value is a JSON object containing the following fields:
 - 'status' The FTP response status e.g. 200.
 - 'text' The FTP response human-readable text.
- 'smtp_command'
 - Emitted when `action` is `smtp_response`. The value is a JSON object containing the following fields:
 - 'command' The SMTP command.
- 'smtp_response'
 - Emitted when `action` is `smtp_response`. The value is a JSON object containing the following fields:
 - 'status' The SMTP response status.
 - 'text' The SMTP response human-readable text.
- 'smtp_data'
 - Emitted when `action` is `smtp_data`. The value is a JSON object containing the following fields:
 - 'from' The value of the SMTP MAIL FROM field, a string.
 - 'to' A list of strings containing all SMTP RCPT TO field values.
 - 'body' The SMTP email body.
- 'gre'
 - Emitted when `action` is `gre`. The value is a JSON object containing the following fields:
 - 'next_proto'
 - The value of the PROTOCOL TYPE field, a string.
 - 'key'
 - The value of the KEY field, a 32 bit number. Defaults to 0 if it is not present in the data frame.
 - 'sequenceNo'
 - The value of the SEQUENCE NUMBER field, a 32 bit number. Defaults to 0 if it is not present in the data frame.

- 'payload' The GRE payload
- 'gre_pptp'
 - Emitted when `action` is `gre_pptp`. The value is a JSON object containing the following fields:
 - 'next_proto'
 - The value of the PROTOCOL TYPE field, a string.
 - 'call_id' The value of the CALL ID field, a 16 bit number.
 - 'sequenceNo'
 - The value of the SEQUENCE NUMBER field, a 32 bit number. Defaults to 0 if it is not present in the data frame.
 - 'acknowledgement_number'
 - The value of the ACKNOWLEDGEMENT NUMBER field, a 32 bit number. Defaults to 0 if it is not present in the data frame.
 - 'payload_length'
 - The length of the GRE PPTP payload
 - 'payload' The GRE payload
- 'esp'
 - Emitted when `action` is `esp`. The value is a JSON object containing the following fields:
 - 'spi'
 - The value of the SPI field, a 32 bit number.
 - 'sequenceNo'
 - The value of the SEQUENCE NUMBER field, a 32 bit number.
 - 'payload_length'
 - The length of the ESP payload
 - 'payload' NOT CURRENTLY OUTPUT, but couple be enabled in the lua config The ESP payload
- 'unrecognised_ip_protocol'
 - Emitted when `action` is `unrecognised_ip_protocol`. The value is a JSON object containing the following fields:
 - 'next_proto'
 - The value of the PROTOCOL field in the IP header.
 - 'sequenceNo'
 - The value of the SEQUENCE NUMBER field, a 32 bit number.
 - 'payload_length'
 - The length of the IP payload
 - 'payload' The IP payload
- '802.11'
 - Emitted when `802.11` is `unrecognised_ip_protocol`. The value is a JSON object containing the following fields:
 - 'version' The value of the VERSION field in the header, an 8 bit number.

<code>'type'</code>	The value of the TYPE field, an 8 bit number.														
<code>'subtype'</code>	The value of the SUBTYPE field, an 8 bit number.														
<code>'flags'</code>	The flags field, an 8 bit number														
<code>'protected'</code>	Indicates if the protected flag is set, a boolean														
<code>'filt_addr'</code>	The MAC address in the FILTER ADDRESS field, a string.														
<code>'frag_num'</code>	The value in the FRAGMENTATION NUMBER field, an 8 bit number.														
<code>'seq_num'</code>	The value in the SEQUENCE NUMBER field, a 16 bit number														
<code>'duration'</code>	The value in the DURATION field, a 16 bit number														
<code>'tls_unknown'</code>	Emitted when <code>action</code> is <code>tls_unknown</code> . The value is a JSON object containing the following fields:														
<code>'tls'</code>	<table> <tr> <td><code>'version'</code></td> <td>The version of the TLS header.</td> </tr> <tr> <td><code>'content_type'</code></td> <td>The content type of the TLS message.</td> </tr> <tr> <td><code>'length'</code></td> <td>The length of the TLS message.</td> </tr> </table>	<code>'version'</code>	The version of the TLS header.	<code>'content_type'</code>	The content type of the TLS message.	<code>'length'</code>	The length of the TLS message.								
<code>'version'</code>	The version of the TLS header.														
<code>'content_type'</code>	The content type of the TLS message.														
<code>'length'</code>	The length of the TLS message.														
<code>'tls_client_hello'</code>	Emitted when <code>action</code> is <code>tls_client_hello</code> . The value is a JSON object containing the following fields:														
<code>'tls'</code>	<table> <tr> <td><code>'version'</code></td> <td>The version requested in the hello message.</td> </tr> <tr> <td><code>'session_id'</code></td> <td>The session id of the message.</td> </tr> <tr> <td><code>'random'</code></td> <td> <table> <tr> <td><code>'timestamp'</code></td> <td>The timestamp field of the random field of the hello message.</td> </tr> <tr> <td><code>'data'</code></td> <td>The data field of the random field of the hello message.</td> </tr> </table> </td> </tr> <tr> <td><code>'cipher_suites'</code></td> <td>An ordered array of the cipher suites names</td> </tr> <tr> <td><code>'compression_methods'</code></td> <td>An ordered array of the compression methods names</td> </tr> </table>	<code>'version'</code>	The version requested in the hello message.	<code>'session_id'</code>	The session id of the message.	<code>'random'</code>	<table> <tr> <td><code>'timestamp'</code></td> <td>The timestamp field of the random field of the hello message.</td> </tr> <tr> <td><code>'data'</code></td> <td>The data field of the random field of the hello message.</td> </tr> </table>	<code>'timestamp'</code>	The timestamp field of the random field of the hello message.	<code>'data'</code>	The data field of the random field of the hello message.	<code>'cipher_suites'</code>	An ordered array of the cipher suites names	<code>'compression_methods'</code>	An ordered array of the compression methods names
<code>'version'</code>	The version requested in the hello message.														
<code>'session_id'</code>	The session id of the message.														
<code>'random'</code>	<table> <tr> <td><code>'timestamp'</code></td> <td>The timestamp field of the random field of the hello message.</td> </tr> <tr> <td><code>'data'</code></td> <td>The data field of the random field of the hello message.</td> </tr> </table>	<code>'timestamp'</code>	The timestamp field of the random field of the hello message.	<code>'data'</code>	The data field of the random field of the hello message.										
<code>'timestamp'</code>	The timestamp field of the random field of the hello message.														
<code>'data'</code>	The data field of the random field of the hello message.														
<code>'cipher_suites'</code>	An ordered array of the cipher suites names														
<code>'compression_methods'</code>	An ordered array of the compression methods names														

```
    'extensions'
        An ordered array of the extensions, in the form of an
        object with the keys name, length and data. (data
        will only be present if length > 0)

'tls_server_hello'
    Emitted when action is tls_server_hello. The value is a JSON object con-
    taining the following fields:

    'tls'

        'version'  The version requested in the hello message.

        'session_id'
            The session id of the message.

        'random'

            'timestamp'
                The timestamp field of the random field of
                the hello message.

            'data'  The data field of the random field of the
                hello message.

        'cipher_suite'
            The name of the cipher suite

        'compression_method'
            The name of the compression methods

        'extensions'
            An ordered array of the extensions, in the form of an
            object with the keys name, length and data. (data
            will only be present if length > 0)

'tls_certificates'
    Emitted when action is tls_certificates. The value is a JSON object con-
    taining the following fields:

    'tls'

        'certificates'
            An ordered array of base64 encoded certificates.

'tls_server_key_exchange'
    Emitted when action is tls_server_key_exchange. The value is a JSON
    object containing the following fields:

    'tls'

        'key_exchange_algorithm'
            The key exchange algorithm being used.

        'curve_type'
            The curve type field.
```

<code>'curve_metadata'</code>	Metadata about the curve being used. In the format of an object of Key:Value pairs. (usually this will only contain 'name' and the value will be the named curve being used)
<code>'public_key'</code>	Base64 encoded public key.
<code>'signature_hash_algorithm'</code>	The type of hash algorithm used for the signature.
<code>'signature_algorithm'</code>	The type of algorithm used for the signature.
<code>'signature_hash'</code>	The signature hash as a hex string
<code>'tls_server_hello_done'</code>	Emitted when action is <code>tls_server_hello_done</code> . The value is an empty JSON object with the key <code>tls</code>
<code>'tls_handshake_unknown'</code>	Emitted when action is <code>tls_handshake_unknown</code> . The value is a JSON object containing the following fields: <code>'tls'</code> <ul style="list-style-type: none"><code>'type'</code> The type of the handshake message.<code>'length'</code> The length of the message.
<code>'tls_certificate_request'</code>	Emitted when action is <code>tls_certificate_request</code> . The value is a JSON object containing the following fields: <code>'tls'</code> <ul style="list-style-type: none"><code>'cert_types'</code> An ordered array of the certificate types.<code>'signature_algorithms'</code> An ordered array of the signature algorithms, each one an object with the keys <code>hash_algorithm</code> and <code>signature_algorithm</code>.<code>'distinguished_names'</code> The distinguished names field.
<code>'tls_client_key_exchange'</code>	Emitted when action is <code>tls_client_key_exchange</code> . The value is a JSON object containing the following fields: <code>'tls'</code> <ul style="list-style-type: none"><code>'key'</code> Base64 encoded key.

- `'tls_certificate_verify'`
Emitted when action is `tls_certificate_verify`. The value is a JSON object containing the following fields:
- `'tls'`
 - `'signature_algorithm'`
The signature algorithm as an object with the keys `hash_algorithm` and `signature_algorithm`.
 - `'signature'`
The signature hash as a hex string.
- `'tls_change_cipher_spec'`
Emitted when action is `tls_change_cipher_spec`. The value is a JSON object containing the following fields:
- `'tls'`
 - `'value'` The value from the change cipher spec message.
- `'tls_handshake_finished'`
Emitted when action is `tls_handshake_finished`. The value is a JSON object containing the following fields:
- `'tls'`
 - `'message'` base64 encoded message.
- `'tls_handshake_complete'`
Emitted when action is `tls_handshake_complete`. The value is an empty JSON object with the key `tls`
- `'tls_application_data'`
Emitted when action is `tls_application_data`. The value is a JSON object containing the following fields:
- `'tls'`
 - `'version'` The version of TLS being used.
 - `'length'` The length of the message being sent.
- `'location'`
Not emitted by `cybermon`, but can be added to the message by `evs-geoip`. See Section 9.17 [`evs-geoip` invocation], page 79.
- The `location` object contains potentially two child-objects: `src` and `dest`. Both `src` and `dest` may contain the following fields, if the information is known:
- `'city'` Name of the city from the GeoIP database.
 - `'iso'` Country ISO code, 2 characters.
 - `'country'` Country name.
 - `'latitude'`
Latitude, degrees north of the equator.

`'longitude'`
Longitude, degrees east of Greenwich.

`'indicators'`
Not emitted by `cybermon`, but can be added to the message by `evs-detector`. See Section 9.18 [`evs-detector` invocation], page 79.

The `indicators` object is an array of IOC hits, if any have been detected. Each array element is an object with the following fields:

`'id'` IOC identifier.

`'type'` IOC type, one of: `ipv4`, `hostname`, `tcp`, `udp`, `hostname`, `email`, `url`.

`'value'` IOC hit value.

`'description'`
Human-readable text describing the IOC.

`'category'`
Category tag for the indicator.

`'source'` Indicator source, a URL, could be the URL of a web page or report.

`'author'` Email address of the originator.

9.12 Cybermon protobuf event format

Cybermon's `'pulsar.lua'` configuration file transmit messages in protobuf format to a Pulsar exchange.

The `cyberprobe.proto` file in the source code contains the protobuf definition. The format is decoded by pub/sub subscribers in the Cyberprobe source code `subscribers` directory if you want a good starting point to code your own. See <https://github.com/cybermageddon/cyberprobe/tree/master/subscribers>.

See <https://github.com/cybermageddon/cyberprobe/blob/master/protos/cyberprobe.proto> for the protobuf definition file.

9.13 evs-monitor invocation

`evs-monitor` subscribes to a pub/sub topic for `cybermon` events, and upon receipt of events, formats them for output in a human-readable manner.

Synopsis:

```
evs-monitor [BINDING]
```

Example:

```
evs-monitor
evs-monitor cyberprobe
```

`'BINDING'` Specifies the pub/sub topic to connect to. If not specified, defaults to `'cyberprobe'`.

9.14 evs-elasticsearch invocation

`evs-elasticsearch` subscribes to a pub/sub topic for `cybermon` events, and upon receipt of events, formats them for delivery to an ElasticSearch store.

Synopsis:

```
evs-elasticsearch [BINDING [ELASTICSEARCH-URL] ]
```

Example:

```
evs-elasticsearch
evs-elasticsearch ioc http://elastic-store:9200/
```

‘`BINDING`’ Specifies the pub/sub topic to connect to. If not specified, defaults to ‘`ioc`’.

‘`ELASTICSEARCH-URL`’

Specifies the base URL for ElasticSearch. If not specified, defaults to ‘`http://localhost:9200`’.

9.15 evs-gaffer invocation

`evs-gaffer` subscribes to a pub/sub topic for `cybermon` events, and upon receipt of events, formats them for delivery to a Gaffer store. The format used is intended to allow Gaffer to be used as an RDF store with SPARQL query. To query and visualise the data stored in Gaffer, see <https://github.com/cybermageddon/gaffer-tools>. To get started with Gaffer quickly, a docker container for development can be found at <https://docker.io/cybermageddon/gaffer>.

Synopsis:

```
evs-gaffer [BINDING [GAFFER-URL] ]
```

Example:

```
evs-gaffer
evs-gaffer ioc \
http://gaffer-store:8080/rest/v1
```

‘`BINDING`’ Specifies the pub/sub topic to connect to. If not specified, defaults to ‘`ioc`’.

‘`GAFFER-URL`’

Specifies the base URL for Gaffer. If not specified, defaults to ‘`http://gaffer:8080/example-rest/v1`’.

9.16 evs-cassandra invocation

`evs-cassandra` subscribes to a Pulsar pub/sub topic for `cybermon` events, and upon receipt of events, formats them for delivery to a Cassandra store. The format used is intended to allow Cassandra to be used as an RDF store with SPARQL query. To query and visualise the data stored in Cassandra, see <https://github.com/cybermageddon/cassandra-redland>.

Synopsis:

```
evs-cassandra [BINDING [CASSANDRA-HOSTS] ]
```

Example:

```
evs-cassandra
```



```
evs-cassandra ioc cassandra1,cassandra2
```

‘**BINDING**’ Specifies the pub/sub topic to connect to. If not specified, defaults to ‘**ioc**’.

‘**CASSANDRA-HOSTS**’

Specifies a comma-separated list of Cassandra store hosts to contact. If not specified, defaults to ‘**localhost**’.

9.17 evs-geoip invocation

evs-geoip subscribes to a pub/sub topic for **cybermon** events, adds location information from GeoIP, and re-publishes the elaborated events. This effectively creates a processing chain. The event subscription and publishing events should be different in order to avoid creating an infinite loop.

Synopsis:

```
evs-geoip [BINDING [PUBLICATION] ]
```

Example:

```
evs-geoip
evs-geoip cyberprobe geo
```

‘**BINDING**’ Specifies the pub/sub topic to connect to. If not specified, defaults to ‘**cyberprobe**’.

‘**PUBLICATION**’

Specifies the pub/sub topic to publish to. If not specified, defaults to ‘**geo**’.

9.18 evs-detector invocation

evs-detector subscribes to a pub/sub topic for **cybermon** events, inspects them for IOCs, and adds detection information if IOCs are observed before re-publishing the elaborated events. This effectively creates a processing chain. The event subscription and publishing events should be different in order to avoid creating an infinite loop.

The indicator file is specified by the ‘**INDICATORS**’ environment variable, the default is **indicators.json**. The file format is the Section 9.19 [Cyberprobe indicator format], page 79. When the file changes, the indicators are reloaded without the needed to restart **evs-detector**.

Synopsis:

```
evs-detector [BINDING [PUBLICATION] ]
```

Example:

```
evs-detector
evs-detector geo ioc
```

‘**BINDING**’ Specifies the pub/sub topic to connect to. If not specified, defaults to ‘**geo**’.

‘**PUBLICATION**’

Specifies the pub/sub topic to publish to. If not specified, defaults to ‘**ioc**’.

9.19 Cyberprobe indicator format

Overview

The `evs-detector` subscriber implements detection against a set of indicators (see Section 9.18 [`evs-detector` invocation], page 79). The indicators are presented in a file containing JSON describing the indicators.

Indicators consist of two parts:

- A boolean expression which describes what to look for.
- A descriptor which describes changes made to the output event when an indicator selects data.

Overall structure

The indicators file consists of a simple header containing the `'description'` and `'version'` fields. The `'version'` field is intended to record a revision history identified for the indicators, and should be changed to a unique value when an update occurs.

These fields are not used by `evs-detector`.

```
{
  "description": "Some test data",
  "version": "1",
  "indicators": [
    ...
  ]
}
```

The `'indicators'` field consists of a list of indicators.

Indicator

An indicator consists of: an ID, a descriptor which is tagged onto events when they hit indicators, and a definition of what to hit on. The example below shows ID and descriptor.

```
{
  "id": "6b7aa83f-8c43-4aaa-817f-5039adef19ef",
  "descriptor": {
    "description": "URL of a page serving malware",
    "category": "malware",
    "author": "someone@example.com",
    "source": "id:3245edd9-e0f3-4982-9406-fbf93b874555",
    "type": "url",
    "value": "http://malware.org/malware.dat"
  },
  ...
}
```

A descriptor contains a type/value pair which is a seed of information that an investigator would want to search for for further information.

The descriptor fields are:

`'description'`

A human-readable description of the purpose of this indicator.

<code>'category'</code>	A threat category for the indicator, which is used to group threats into type of threat
<code>'author'</code>	Email address of indicator author
<code>'source'</code>	Source of the indicator, should be a URL e.g. a web-page address of a report
<code>'type'</code>	The type of the <code>'value'</code> field, can be one of <code>'hostname'</code> , <code>'url'</code> , <code>'ipv4'</code> , <code>'ipv6'</code> , <code>'tcp'</code> , <code>'udp'</code> , <code>'email'</code> .

Indicator value

The indicator value consists of four constructs:

- `'and'`
- `'or'`
- `'not'`
- Match term

The value construct is included in the Indicator object alongside the `'id'` field e.g.

```

{
  "id": "845bcc85-49f5-427c-806c-5fe5984c2c5c",
  "descriptor": {
    ...
  },
  "type": "tcp",
  "value": "11111"
}
or
{
  "id": "845bcc85-49f5-427c-806c-5fe5984c2c5c",
  "descriptor": {
    ...
  },
  "or": [
    {
      "type": "tcp",
      "value": "11111"
    },
    {
      "type": "tcp",
      "value": "11112"
    }
  ]
}

```

The four value constructs can be combined with multiple layers to any depth.

Match term

The simple matching form consists of a type and value. The type field can be one of: 'hostname', 'url', 'ipv4', 'ipv4.src', 'ipv4.dest', 'ipv6', 'ipv6.src', 'ipv6.dest', 'tcp', 'tcp.src', 'tcp.dest', 'udp', 'udp.src', 'udp.dest', 'email'. e.g.

```
{
  "type": "ipv4.src",
  "value": "192.168.0.1"
}
```

'and' construct

The 'and' construct is true if all of its children are true.

```
"and": [
  {
    "type": "hostname",
    "value": "example.com"
  },
  {
    "type": "tcp",
    "value": "11112"
  }
]
```

'or' construct

The 'or' construct is true if any of its children are true.

```
"or": [
  {
    "type": "hostname",
    "value": "example.com"
  },
  {
    "type": "hostname",
    "value": "example.com"
  }
]
```

'not' construct

The 'not' construct is true if its child is false.

```
"not": {
  "type": "hostname",
  "value": "example.com"
}
```

Threat exchanges

See <https://github.com/cybermageddon/threat-exchanges> for code which creates indicator sets from threat exchanges.

9.20 evs-dump invocation

`evs-dump` subscribes to a pub/sub topic for `cybermon` events, and dumps the raw JSON to standard output.

Synopsis:

```
evs-dump [BINDING]
```

Example:

```
evs-dump
evs-dump cyberprobe
```

‘`BINDING`’ Specifies the pub/sub topic to connect to. If not specified, defaults to ‘`cyberprobe`’.

9.21 evs-alert invocation

`evs-alert` subscribes to a pub/sub topic for `cybermon` events, and outputs a human-readable message when an IOC hits.

Synopsis:

```
evs-alert [BINDING]
```

Example:

```
evs-alert
evs-alert ioc
```

‘`BINDING`’ Specifies the pub/sub topic to connect to. If not specified, defaults to ‘`ioc`’.

9.22 taxii-client invocation

`taxii-client` provides a means to connect with a TAXII compliant server to acquire cyber threat information. TAXII/STIX implementation is experimental and incomplete.

See <https://taxii.mitre.org/> for more information on TAXII and STIX. Synopsis:

```
taxii-client [-h] [--host HOST] [--port PORT] [--path PATH]
             [--collection COLLECTION] [--begin_timestamp BEGIN_TS]
             [--end_timestamp END_TS] [--discovery] [--poll]
             [--collection_information] [--subscribe] [--action ACT]
             [--query QUERY] [--subs-id SUBSCRIPTION_ID]
             [--inbox INBOX]
```

Example:

```
taxii-client -h taxii.com --poll
```

‘`-h`’

‘`--help`’ Shows command line usage.

‘`--host HOST`’

Specifies host to connect to.

‘`--port PORT`’

Specifies port number of the TAXII service.

- `--path PATH`
Specifies the URI of the service. Default is `'/'`.
- `--collection COLLECTION`
Specifies the TAXII collection to use. Default is `'default'`.
- `--begin_timestamp BEGIN`
Specifies the TAXII collection to use. Default is `'default'`.
- `--end_timestamp END`
Specifies the TAXII collection to use. Default is `'default'`.
- `--discovery`
Invokes a TAXII discovery action.
- `--poll`
Invokes a TAXII poll action.
- `--collection_information`
Invokes a collection information action.
- `--subscribe`
Invokes a TAXII subscribe action.
- `--action ACT`
Specifies the subscription action to perform.
- `--query QUERY`
Specifies the query to use for an inbox or poll action. Query takes the form: `'type:value'`. Type can be one of:
- `'address'` CyBOX address object value e.g. `'address:1.2.3.4'`
 - `'addresstype'`
CyBOX address object type e.g. `'addresstype:e-mail'`
 - `'domainname'`
CyBOX DNS name
 - `'port'` TCP/UDP port number e.g. `'port:11111'`
 - `'hash'` File object hash value.
 - `'id'` Object ID.
 - `'source'` Object source identifier.
- Multiple query values may be specified in which case they are combined with a logical AND.
- `--subs-id SUBS-ID`
Specifies the subscription ID for a subscription operation.
- `--inbox INBOX`
Specifies the inbox destination for subscriptions. The default value is `http://localhost:8888/`.

Begin/end timestamps take the following form:

YYYY-MM-DDTHH:MM:SS.ssssss+/-hh:mm

9.23 taxii-sync-json invocation

`taxii-sync-json` provides a means to connect with a TAXII compliant server to acquire cyber threat information. `taxii-sync-json` uses a TAXII poll request, and reformats all STIX information into a single JSON file which is written to the current directory. This JSON form is intended to be used with `evs-detector`. See Section 9.18 [`evs-detector` invocation], page 79.

TAXII/STIX implementation is experimental and incomplete.

See <https://taxii.mitre.org/> for more information on TAXII and STIX. Synopsis:

```
taxii-sync-json [-h] [--host HOST] [--port PORT] [--path PATH]
                [--collection COLLECTION] [--begin_timestamp BEGIN_TS]
                [--end_timestamp END_TS]
```

Example:

```
taxii-sync-json -h taxii.com
```

‘-h’

‘--help’ Shows command line usage.

‘--host *HOST*’

Specifies host to connect to.

‘--port *PORT*’

Specifies port number of the TAXII service.

‘--path *PATH*’

Specifies the URI of the service. Default is ‘/’.

‘--collection *COLLECTION*’

Specifies the TAXII collection to use. Default is ‘default’.

‘--begin_timestamp *BEGIN*’

Specifies the TAXII collection to use. Default is ‘default’.

‘--end_timestamp *END*’

Specifies the TAXII collection to use. Default is ‘default’.

The JSON information is written to the current directory to a file called `stix-COLLECTION-combined.json` where *COLLECTION* is the collection name chosen.

Begin/end timestamps take the following form:

```
YYYY-MM-DDTHH:MM:SS.ssssss+/-hh:mm
```

9.24 taxii-server invocation

`taxii-server` provides a TAXII compliant server to distribute cyber threat information. TAXII/STIX implementation is experimental and incomplete.

See <https://taxii.mitre.org/> for more information on TAXII and STIX. Synopsis:

```
taxii-server [-h] [--host HOST] [--port PORT] [--data-dir DATA_DIR]
              [--db DB] [--sync-period SYNC_PERIOD]
```

Example:

```
taxii-server --port 8100 --data-dir data/ --db stix.db
```

‘-h’

‘--help’ Shows command line usage.

‘--host *HOST*’

Host to bind the HTTP service to.

‘--port *PORT*’

Specifies port number of the TAXII service.

‘--data-dir *PATH*’

Specifies the directory where STIX files are to be placed. Directory structure should be *PATH/COLLECTION/STIX-FILE*.

‘--db *DB*’ Specifies a file to hold the STIX data. Default is *stix_store.db*. This is created if it does not exist.

‘--sync-period *PERIOD*’

Specifies the period for synchronising the data directory with the database. Default is ‘1’.

The TAXII server periodically checks the data directory with the contents of the database, and updates the database accordingly. Deleting files results in deletion from the database, adding files results in creation. Thus, the data directory is the master copy for the sync process.

9.25 nhis11-rcvr invocation

nhis11-rcvr provides a TCP server which accepts connections from NHIS LI clients, decodes NHIS LI streams and outputs contained IP packets on the standard output in PCAP format. TCP port number to use is provided on the command line. Synopsis:

```
nhis11-rcvr port-number
```

- *port-number* is the TCP port number to list to for connections. See [NHIS LI], page 40.

nhis11-rcvr executes indefinitely - to end the program, a signal should be sent. e.g.

```
killall nhis11-rcvr
```

9.26 etsi-rcvr invocation

etsi-rcvr provides a TCP server which accepts connections from ETSI LI clients, decodes ETSI LI streams and outputs contained IP packets on the standard output in PCAP format. TCP port number to use is provided on the command line. Synopsis:

```
etsi-rcvr port-number
```

- *port-number* is the TCP port number to list to for connections. See [ETSI LI], page 40.

etsi-rcvr executes indefinitely - to end the program, a signal should be sent. e.g.

```
killall etsi-rcvr
```

9.27 Elasticsearch model

Overview

When `evs-elasticsearch` is used observations are created in an Elasticsearch database. These configuration files call the `elastic.lua` utility module. This section describes the data model used in the Elasticsearch database.

ElasticSearch accepts data in JSON form. `evs-elasticsearch` uses an index called `cyberprobe` and an object type `observation`.

Here is an example of a JSON payload which is emitted for a DNS request:

```
{
  "observation": {
    "type": "query",
    "answers": {},
    "device": "123456",
    "dest": {
      "udp": ["53"],
      "dns": [],
      "ipv4": ["192.168.1.1"]
    },
    "queries": {
      "name": ["news.bbc.co.uk"],
      "type": ["1"],
      "class": ["1"]
    },
    "src": {
      "udp": ["57291"],
      "dns": [],
      "ipv4": ["192.168.1.100"]
    },
    "time": "20141018T175059.366Z",
    "action": "dns_message",
    "id": 1
  }
}
```

Common fields

The following fields are emitted for all observations:

`observation`

This is a JSON object which describes a Cyberprobe observation.

`observation.oid`

A unique object ID.

`observation.time`

Describes the time of the event in GMT. The components are:

- 4-digit year

- 2-digit month
- 2-digit date
- Literal 'T'.
- 2-digit hour (24-hour).
- 2-digit minute
- 2-digit second
- Literal '.'
- 3-digit milliseconds
- Literal 'Z'

e.g. 20141018T175059.366Z.

observation.device

A string containing the targeted LIID / device ID.

observation.action

Describes the type of a Cyberprobe observation. See [Actions], page 88, below.

observation.src

An object describing the full stack of protocol destination addresses. For each name/value pair, the name is the protocol name, and the value is an array of strings which are protocol addresses. For example:

```
"src": {
  "udp": ["57291"],
  "dns": [""],
  "ipv4": ["192.168.1.100"]
}
```

This specifies a UDP source port number of 57291, and an IP source address of 192.168.1.100. Each protocol layer is list, allowing for more than one address - protocol tunnels may result in more than IP address, for instance.

observation.dest

An object describing the full stack of protocol destination addresses, like **observation.src** above, but for destination addresses.

Actions

The following **action** fields are defined:

'connected_up'

Records the creation of a stream-orientated connection (currently, only TCP). This event is created for all connections whether the protocol is recognised or not.

'connected_down'

Records the closing of a stream-orientated connection (currently, only TCP). This event is created for all connections whether the protocol is recognised or not.

- `'unrecognised_stream'`
Records the sending of a PDU on a connection-less transport (currently, only UDP) whose protocol has not been recognised.
- `'unrecognised_datagram'`
Records the sending of a PDU on a connection-less transport (currently, only UDP) whose protocol has not been recognised.
- `'http_request'`
Records the sending of an HTTP request.
- `'http_response'`
Records the sending of an HTTP response.
- `'dns_message'`
Records the sending of a DNS message (request and response).
- `'icmp'`
Records the sending of an ICMP message.
- `'smtp_command'`
Records the sending of an SMTP command. This is a message from client to server. Data commands are not recorded with this event - there is an `'smtp_data'` event which records this.
- `'smtp_response'`
Records the sending of a response to an SMTP command. This is a status message from server to client.
- `'smtp_data'`
Records an SMTP data transaction, including the full SMTP data payload (essentially an email).
- `'ftp_command'`
Records an FTP command (client to server).
- `'ftp_response'`
Records an FTP response (server to client).

Connection up

Connection up events are created when connection-orientated transports (e.g. TCP) are created, and have an `action` field of `'connection_up'`.

Connection down

Connection down events are created when connection-orientated transports (e.g. TCP) are closed and have an `action` field of `'connection_down'`.

Unrecognised datagram

Unrecognised datagram events are created when a datagram is observed on an unrecognised protocol, and have an `action` field of `'unrecognised_datagram'`. Such events include the following fields:

- `observation.data`
The datagram payload, base64 encoded.

Unrecognised stream

Unrecognised stream events are created when data is observed to be sent on an unrecognised connection-orientated protocol (e.g. TCP), and have an `action` field of `'unrecognised_stream'`. Such events include the following fields:

`observation.data`

The datagram payload, base64 encoded.

ICMP

ICMP events are created when an ICMP message is observed and have an `action` field of `'icmp'`. Such events include the following fields:

`observation.data`

The datagram payload, base64 encoded.

DNS messages

DNS events are created for DNS query and response messages, and have an `action` field of `'dns_message'`. Such events include the following fields:

`observation.type`

Used to describe the type of a DNS message, by interpreting the message flags. Will be `'query'` or `'response'`.

`observation.queries`

Contains a list of DNS queries. Example:

```
"queries": [
  {
    "class": "1",
    "name": "news.bbc.co.uk",
    "type": "1"
  }
]
```

`observation.answers`

Contains a list of DNS responses. Example:

```
"answers": [
  {
    "class": "1",
    "name": "newswww.bbc.net.uk",
    "type": "1"
  },
  {
    "class": "1",
    "address": "212.58.246.85",
    "name": "newswww.bbc.net.uk",
    "type": "1"
  }
]
```

```

    },
    {
      "class": "1",
      "address": "212.58.246.84",
      "name": "newswww.bbc.net.uk",
      "type": "1"
    }
  ]

```

HTTP request

HTTP request events are created for HTTP requests, and have an `action` field of `'http_request'`. Such events include fields:

`observation.method`

The HTTP method e.g. `'GET'`, `'POST'`.

`observation.url`

The HTTP URL e.g. `'http://www.bbc.co.uk/index.html'`.

`observation.header`

An object containing the request headers e.g.

```

{
  "Accept": "*/*",
  "Referer": "http://www.bbc.co.uk/news/",
  "Accept-Language": "en-gb,en;q=0.5",
  "Host": "www.bbc.co.uk",
  "Accept-Encoding": "gzip, deflate",
  "Connection": "keep-alive",
  "User-Agent": "Test/5.0"
}

```

`observation.body`

Describes the HTTP body. This is a base64 encoding of the body.

HTTP response

HTTP response events are created for responses to HTTP requests, and have an `action` field of `'http_response'`. Such events include the following fields:

`observation.code`

The HTTP status code e.g. `'200'`.

`observation.status`

The HTTP status response e.g. `'OK'`.

`observation.url`

The HTTP URL e.g. `'http://www.bbc.co.uk/index.html'`. This is obtained by studying the HTTP request, so will only be present where the HTTP request is observed.

observation.header

An object containing the response headers e.g.

```
{
  "Server": "Apache",
  "Content-Type": "text/javascript"
}
```

observation.body

Describes the HTTP response body, base64 encoded.

SMTP command

SMTP commands events are created when an SMTP command is sent from client to server, and have an `action` field of `'smtp_command'`. Such events include the following fields:

observation.command

The SMTP command e.g. `'EHLO'`.

SMTP response

SMTP response events are created when an SMTP response is sent from server to client, and have an `action` field of `'smtp_response'`. Such events include the following fields:

observation.status

The SMTP status e.g. `'400'`.

observation.text

The SMTP text e.g. `'["Hello malware.com. Pleased to meet you."']'`.

SMTP data

SMTP data events are created when an SMTP email is sent from client to server, and have an `action` field of `'smtp_data'`. Such events include the following fields:

observation.from

The SMTP “from” address. A string.

observation.to

The SMTP “to” addresses. An array of strings.

observation.data

The SMTP payload (RFC822), base64 encoded.

FTP command

FTP commands events are created when an FTP command is sent from client to server, and have an `action` field of `'ftp_command'`. Such events include the following fields:

observation.command

The FTP command.

FTP response

FTP response events are created when an FTP response is sent from server to client, and have an `action` field of `'ftp_response'`. Such events include the following fields:

`observation.status`
The FTP status.

`observation.text`
The FTP text.

10 Architecture

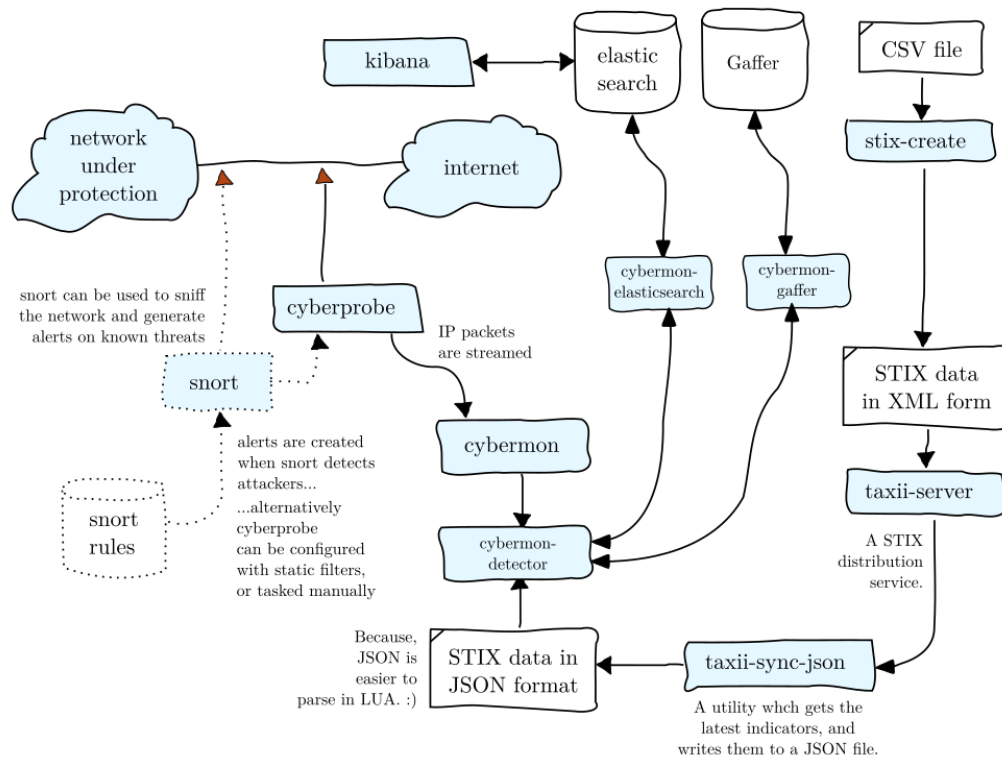

Cyberprobe consists of a set of loosely-coupled components which can be used together. We prefer to use simple interfaces, and prefer to use interfaces which are standards. Here's how we envisage these components being used:

cyberprobe

is a network sniffer which collects packets which match an IP address list. The packets collected are streamed using network streaming protocols. The IP address match list can be statically configured (in a configuration file), can be dynamically changed using a management interface, or can be dynamically changed as a result of Snort alerts.

cybermon receives packets from cyberprobe, analyses them and generates session/transport level events which result in user-configurable actions. For each event, a call is made to a Lua script which the caller provides.

evs-detector

runs events past an IOC list, searching for cyber threat indicators. When these indicators are observed, the indicator meta-data is also added to the JSON events.

pulsar.lua

is a cybermon configuration file we provide which publishes data to a Pulsar pub/sub exchange. It allows connection of consumers to the cybermon event stream.

evs-cassandra

is an event subscriber which output `cybermon` events to a Cassandra store.

evs-elasticsearch

is an event subscriber which output `cybermon` events to a ElasticSearch store.

evs-gaffer

is an event subscriber which output `cybermon` events to a Gaffer store.

taxii-server

is a TAXII compliant server, which is used to distribute STIX rules over HTTP.

taxii-client-json

is a TAXII compliant client, which fetches STIX data over TAXII and write it to a JSON file in a way that `stix+db.lua` can read.

snort

is not part of cyberprobe, but it's a great NIDS, so we use that.

Index

A

action..... 49
 Actions..... 88
 Alert..... 83
 Amazon Linux..... 6
 AMQP..... 64, 66
 Apache Cassandra..... 28, 78, 95
 Apache Pulsar..... 64
apt-get..... 5
 Architecture..... 94
 Authentication..... 13
 AWS Traffic Mirroring..... 33, 36, 48

B

Boost..... 8
 Build dependencies..... 8
 Build targets..... 9
 Building..... 9

C

Cassandra..... 28, 78, 95
certificate, cyberprobe configuration option.. 37
 Checkout from git repository..... 7
 Compilation..... 9
connected_up..... 20
 Connection down..... 89
 Connection reset..... 13
 Connection restart..... 13
 Connection up..... 89
 Containers..... 7, 31
context..... 20, 21
context object..... 62
control..... 35
cybermon..... 1, 2, 9, 17
cybermon context object..... 62
cybermon events..... 49
 Cybermon JSON message format.... 64, 65, 66, 83
 Cybermon protobuf event format..... 64, 77
cybermon, configuration..... 17, 64
cybermon, docker repository..... 7
cybermon, example configurations..... 64
cybermon, features..... 2
cybermon, invocation..... 48
cybermon, pub/sub..... 27, 28
cybermon, **pulsar.lua** configuration file..... 94
cyberprobe..... 1, 2, 9, 10
cyberprobe configuration..... 10
cyberprobe secure delivery..... 37
 Cyberprobe, architecture..... 94
cyberprobe, configuration..... 35, 86
cyberprobe, **control**..... 35
cyberprobe, **delay**..... 16, 19

Cyberprobe, docker repository..... 7
cyberprobe, docker repository..... 7
cyberprobe, **endpoint**..... 12
cyberprobe, **endpoints**..... 35
cyberprobe, features..... 2
cyberprobe, **interfaces**..... 35
cyberprobe, invocation..... 35
cyberprobe, management..... 13
cyberprobe, **snort_alert**..... 35
cyberprobe, **target**..... 11
cyberprobe, **targets**..... 35
cyberprobe-cli..... 9, 14
cyberprobe-cli, commands..... 38
cyberprobe-cli, invocation..... 37

D

DAG..... 34
 Dashboard..... 24
 Debian..... 5
Delay..... 16, 19
 dependencies..... 8
 Device ID..... 40, 88
 Discussion forums..... 9
dnf..... 5
dns_message..... 21
 DNS..... 17
 Docker..... 7, 31
 Docker compose..... 31
docker-compose-cp-snort.yml..... 31
docker-compose.yml..... 31
 Downloading..... 9
 DPI..... 1
dpkg..... 5

E

ElasticSearch..... 22, 28, 31, 87, 95
 ElasticSearch model, actions..... 88
 ElasticSearch, model..... 87
 Endace..... 34
 Endpoint..... 12
endpoints..... 35
etsi-rcvr..... 9, 12
etsi-rcvr, invocation..... 86
 ETSI..... 40
 ETSI LI..... 40
 ETSI TS 101 671..... 40
 ETSI TS 102 232-1..... 40
 ETSI TS 102 232-3..... 40
event..... 18, 20, 21
eventstream-service, invocation..... 39
evs-alert..... 9
evs-alert, invocation..... 83

evs-cassandra 9, 95
 evs-cassandra, invocation 28, 78
 evs-detector 9, 77
 evs-detector invocation 94
 evs-detector, invocation 79
 evs-dump 9
 evs-dump, invocation 83
 evs-elasticsearch 9, 95
 evs-elasticsearch, invocation 28, 78
 evs-gaffer 9, 95
 evs-gaffer, invocation 29, 78
 evs-geoip 9, 76
 evs-geoip, invocation 79
 evs-monitor, invocation 30, 77
 Executables 9

F

Features, of cybermon 2
 Features, of cyberprobe 2
 Fedora 5
 Forging, DNS response 21
 FTP command 92
 FTP response 93

G

Gaffer 29, 31, 78, 95
 GeoIP 76, 79
 Getting started 9
 git repository 7
 GLIC 40
 Graph store 28, 29, 78
 gRPC 39, 63, 65, 77

H

http_request 21
 http_response 18
 HTTP request 91
 HTTP response 91

I

ICMP 90
 ifconfig 10
 Indicator 25, 79
 Indicator of compromise 77, 79
 Indicator of Compromise 25
 Installation 9
 Integration with snort 15
 interfaces 35
 IOC 25, 77, 79
 IP address mask 35
 IP address matching 35

J

json.lua 18
 JSON 23, 25, 64, 65, 66, 83

K

key, cyberprobe configuration option 37
 Kibana, dashboard 24

L

libpcap 8
 libtaxii 8
 LIID 40, 88
 Lua 8
 LUA events 49

M

Management 13
 Management client 37, 38
 Management protocol 41
 monitor.lua 17

N

ncurses 8
 network attribute, cyberprobe.cfg 37, 63, 66
 Network parameters 9
 nhis11-rcvr, invocation 86
 NHIS 1.1 40
 NHIS 1.1 LI 40

O

Overview of Cyberprobe 2

P

Packages 9
 Packet forgery 19
 Packet injection 19
 Packet inspection 1
 Privileged user 11
 protobuf 64, 77
 Protobuf 39, 63, 65
 pub/sub 64, 66
 Pub/sub delivery 27, 28
 publish/subscribe 64, 66
 Pulsar 64
 pulsar.lua configuration file 94

Q

queue delivery using Redis 65

R

RabbitMQ 64, 66
readline 8
Reconnection 13
Redis 65, 66
Release history 3

S

SMTP command 92
SMTP data 92
SMTP response 92
Snort 1, 2
snort alerts 16
snort, integration 15
snort, rules 15
snort, signatures 15
snort_alert 35
SSL 37
stix 8
Storing observations 22

T

Target 11
targets 35
targets, address mask 35
taxii-client, invocation 83
taxii-server, invocation 85
taxii-sync-json, invocation 85
TCP reset 19

tcpdump 8
telnet 8
Threat indicator 25
TLS 37
trusted-ca, cyberprobe configuration option ... 37
TS 101 671 40
TS 102 232-1 40
TS 102 232-3 40

U

Ubuntu 5
Unrecognised datagram 89
Unrecognised stream 90

V

Version history 3
Visualisation 22
VXLAN 33, 36, 48

Y

yum 6

Z

ZeroMQ 64, 66